

23 May 2018

Agreement

Concerning the Adoption of Harmonized Technical United Nations Regulations for Wheeled Vehicles, Equipment and Parts which can be Fitted and/or be Used on Wheeled Vehicles and the Conditions for Reciprocal Recognition of Approvals Granted on the Basis of these United Nations Regulations*

(Revision 3, including the amendments which entered into force on 14 September 2017)

Addendum 126: UN Regulation No. 127

Revision 2

Incorporating all valid text up to:

02 series of amendments to the Regulation – Date of entry into force: 18 June 2016

Uniform provisions concerning the approval of motor vehicles with regard to their pedestrian safety performance

This document is meant purely as documentation tool. The authentic and legal binding text is ECE/TRANS/WP.29/2015/99.



UNITED NATIONS

* Former titles of the Agreement:

Agreement concerning the Adoption of Uniform Conditions of Approval and Reciprocal Recognition of Approval for Motor Vehicle Equipment and Parts, done at Geneva on 20 March 1958 (original version); Agreement concerning the Adoption of Uniform Technical Prescriptions for Wheeled Vehicles, Equipment and Parts which can be Fitted and/or be Used on Wheeled Vehicles and the Conditions for Reciprocal Recognition of Approvals Granted on the Basis of these Prescriptions, done at Geneva on 5 October 1995 (Revision 2).

UN Regulation No. 127

Uniform provisions concerning the approval of motor vehicles with regard to their pedestrian safety performance

Contents

	<i>Page</i>
Regulation	
1. Scope	4
2. Definitions.....	4
3. Application for approval	17
4. Approval.....	17
5. Specifications	18
6. Modification of vehicle type and extension of approval	19
7. Conformity of production.....	19
8. Penalties for non-conformity of production	20
9. Production definitively discontinued.....	20
10. Names and addresses of the Technical Services responsible for conducting approval tests and of the Type Approval Authorities	20
11. Transitional provisions	20
Annexes	
1 Part 1 - Model - Information document No ... relating to the type approval of a vehicle with regard to pedestrian protection	22
Part 2 - Communication	24
2 Arrangements of approval marks	26
3 General test conditions	27
4 Test impactor specifications	28
5 Test procedures	37
6 Certification of the impactor	46

1. Scope

This Regulation applies to motor vehicles of categories M₁ and N₁.¹

However, vehicles of category N₁ where the driver's position "R-point" is either forward of the front axle or longitudinally rearwards of the front axle transverse centreline by a maximum of 1,100 mm, are exempted from the requirements of this Regulation.

This Regulation does not apply to vehicles of category M₁ above 2,500 kg maximum mass and which are derived from N₁ category vehicles, and where the driver's position "R-point" is either forward of the front axle or longitudinally rearwards of the front axle transverse centreline by a maximum of 1,100 mm; for these vehicle categories Contracting Parties may continue to apply the requirements already in force for that purpose at the time of acceding to this Regulation.

2. Definitions

When performing measurements as described in this Part, the vehicle should be positioned in its normal ride attitude.

If the vehicle is fitted with a badge, mascot or other structure, which would bend back or retract under an applied load of maximum 100 N, then this load shall be applied before and/or while these measurements are taken.

Any vehicle component which could change shape or position, other than suspension components or active devices to protect pedestrians, shall be set to their stowed position.

For the purposes of this Regulation:

2.1. "*Adult headform test area*" is an area on the outer surfaces of the front structure. The area is bounded:

- (a) In the front, by a wrap around distance (WAD) of 1,700 or a line 82.5 mm rearward of the bonnet leading edge reference line, whichever is most rearward at a given lateral position;
- (b) At the rear, by a WAD 2,100 or a line 82.5 mm forward of the bonnet rear reference line, whichever is most forward at a given lateral position, and
- (c) At each side, by a line 82.5 mm inside the side reference line.

The distance of 82.5 mm is to be set with a flexible tape held tautly along the outer surface of the vehicle.

2.2. "*Assessment Interval (AI)*" of the flexible lower legform impactor is defined and limited by the time of first contact of the flexible lower legform impactor with the vehicle and the timing of the last zero crossing of all femur and tibia segments after their first local maximum subsequent to any marginal value of 15 Nm, within their particular common zero crossing phases. The AI is identical for all bone segments and knee ligaments. In case of any bone

¹ As defined in the Consolidated Resolution on the Construction of Vehicles (R.E.3.), document ECE/TRANS/WP.29/78/Rev.6, para. 2. - www.unece.org/trans/main/wp29/wgs/wp29gen/wp29resolutions.html

segment not having a zero crossing during the common zero crossing phases, the time history curves for all bone segments are shifted downwards until all bending moments are crossing zero. The downwards shift is to be applied for the determination of the AI only.

- 2.3. "*A-pillar*" means the foremost and outermost roof support extending from the chassis to the roof of the vehicle.
- 2.4. "*Approval of a vehicle type*" means the full procedure whereby a Contracting Party to the Agreement certifies that a vehicle type meets the technical requirements of this Regulation.
- 2.5. "*Bonnet leading edge*" means the edge of the front upper outer structure of the vehicle, including the bonnet and wings, the upper and side members of the headlight surrounds and any other attachments. The reference line identifying the position of the bonnet leading edge is defined by its height above the ground reference plane and by the horizontal distance separating it from the bumper (bumper lead).
- 2.6. "*Bonnet leading edge height*" means, at any point on the bonnet leading edge, the vertical distance between the ground reference plane and the bonnet leading edge reference line at that point.
- 2.7. "*Bonnet leading edge reference line*" means the geometric trace of the points of contact between a straight edge 1,000 mm long and the front surface of the bonnet, when the straight edge, held parallel to the vertical longitudinal plane of the car and inclined rearwards by 50° from the vertical and with the lower end 600 mm above the ground, is traversed across and in contact with the bonnet leading edge (see Figure 1).

For vehicles having the bonnet top surface inclined at 50°, so that the straight edge makes a continuous contact or multiple contacts rather than a point contact, the reference line is determined with the straight edge inclined rearwards at an angle of 40° from the vertical.

For vehicles of such shape that the bottom end of the straight edge makes first contact, then that contact is taken to be the bonnet leading edge reference line, at that lateral position.

For vehicles of such shape that the top end of the straight edge makes first contact with the vehicle, then the geometric trace of 1,000 mm wrap around distance will be used as the bonnet leading edge reference line at that lateral position.

The top edge of the bumper shall also be regarded as the bonnet leading edge for the purposes of this Regulation, if it is contacted by the straight edge during this procedure.

Figure 1
Bonnet leading edge reference line

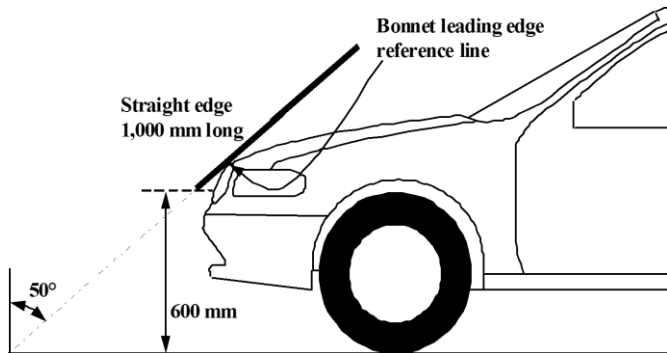

2.8. "Bonnet rear reference line" means the geometric trace of the most rearward points of contact between a 165 mm diameter sphere and the front structure of the vehicle when the sphere is traversed across the front structure of the vehicle while maintaining contact with the windscreen (see Figure 2). The wiper blades and arms are removed during this process.

Where the bonnet rear reference line and the side reference line do not intersect, the bonnet rear reference line should be extended and/or modified using a semi-circular template, of radius 100 mm. The template should be made of a thin flexible sheet material that easily bends to a single curvature in any direction. The template should, preferably, resist double or complex curvature where this could result in wrinkling. The recommended material is a foam backed thin plastic sheet to allow the template to "grip" the surface of the vehicle.

The template should be marked up with four points "A" through "D", as shown in Figure 3, while the template is on a flat surface.

The template should be placed on the vehicle with Corners "A" and "B" coincident with the side reference line. Ensuring these two corners remain coincident with the side reference line, the template should be slid progressively rearwards until the arc of the template makes first contact with the bonnet rear reference line. Throughout the process, the template should be curved to follow, as closely as possible, the outer contour of the vehicle's bonnet top, without wrinkling or folding of the template. If the contact between the template and bonnet rear reference line is tangential and the point of tangency lies outside the arc scribed by points "C" and "D", then the bonnet rear reference line is extended and/or modified to follow the circumferential arc of the template to meet the bonnet side reference line, as shown in Figure 4.

If the template cannot make simultaneous contact with the bonnet side reference line at points "A" and "B" and tangentially with the bonnet rear reference line, or the point at which the bonnet rear reference line and template touch lies within the arc scribed by points "C" and "D", then additional templates should be used where the radii are increased progressively in increments of 20 mm, until all the above criteria are met.

Figure 2
Bonnet rear reference line

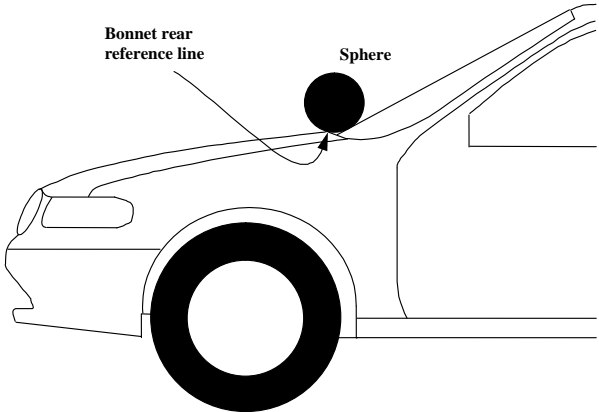

Figure 3
Template

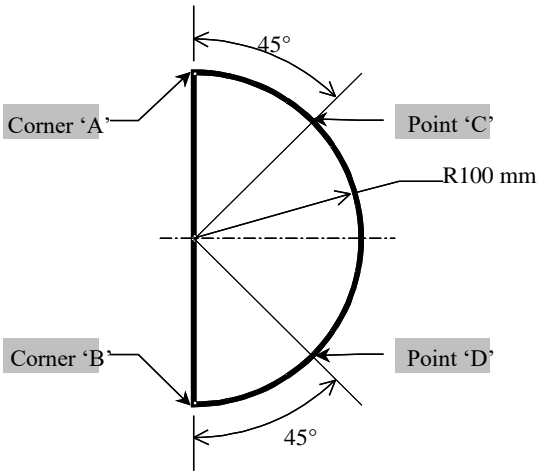
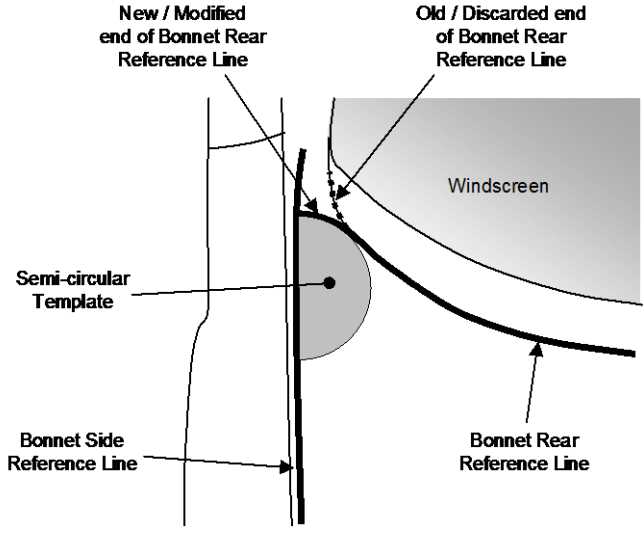

Figure 4
Marking of intersection between bonnet rear and side reference lines



- 2.9. "Bonnet top" is the area which is bounded by (a), (b) and (c) as follows:
- (a) The bonnet leading edge reference line;
 - (b) The bonnet rear reference line;
 - (c) The side reference lines.
- 2.10. "Bonnet top test area" is composed of the child headform test area and the adult headform test area as defined in paragraphs 2.1. and 2.16. respectively.
- 2.11. "Bumper" means the front, lower, outer structure of a vehicle. It includes all structures that are intended to give protection to a vehicle when involved in a low speed frontal collision and also any attachments to this structure. The reference height and lateral limits of the bumper are identified by the corners and the bumper reference lines.
- 2.12. "Bumper beam" means the structural cross member, rearward of the bumper fascia if present, protecting the front of the vehicle. The beam does not include foam, cover support or any pedestrian protection devices.
- 2.13. "Bumper lead" means for any longitudinal section of a vehicle, the horizontal distance measured in any vehicle vertical longitudinal plane between the upper bumper reference line and the bonnet leading edge reference line.
- 2.14. "Bumper test area" means either the front vehicle fascia between the left and right corner of bumper as defined in paragraph 2.17., minus the areas covered by the distance of 42 mm inboard of each corner of bumper as measured horizontally and perpendicular to the longitudinal median plane of the vehicle, or between the outermost ends of the bumper beam as defined in paragraph 2.12. (see Figure 5D), minus the areas covered by the distance of 42 mm inboard of each end of the bumper beam, as measured horizontally and perpendicular to the longitudinal median plane of the vehicle, whichever area is wider.
- 2.15. "Centre of the knee" of the lower legform impactor is defined as the point about which the knee effectively bends.
- 2.16. "Child headform test area" is an area on the outer surfaces of the front structure. The area is bounded:
- (a) In the front, by a WAD 1,000 or a line 82.5 mm rearward of the bonnet leading edge reference line, whichever is most rearward at a given lateral position,
 - (b) At the rear, by a WAD 1,700 or a line 82.5 mm forward of the bonnet rear reference line, whichever is most forward at a given lateral position, and
 - (c) At each side, by a line 82.5 mm inside the side reference line.
- The distance of 82.5 mm is to be set with a flexible tape held tautly along the outer surface of the vehicle.
- 2.17. "Corner of bumper" means the transversal position of the vehicle's point of contact with a corner gauge as defined in Figure 5B.
- For determination of the corner of bumper, the front surface of the corner gauge is moved parallel to a vertical plane with an angle of 60° to the vertical longitudinal centre plane of the vehicle (see Figures 5A and 5C) at any height of the centre point of the corner gauge between:

- (a) Equal to and above the point found on the vertical line intersecting the lower bumper reference line at the assessment position in transversal direction or at 75 mm above the ground reference plane, whichever is higher.
- (b) Equal to and below the point found on the vertical line intersecting the upper bumper reference line at the assessment position in transversal direction or at 1,003 mm above the ground reference plane, whichever is lower.

For determination of the corner of bumper, the gauge is moved to contact the outer contour/front fascia of the vehicle touching at the vertical centre line of the gauge. The horizontal centre line of the gauge is kept parallel to the ground plane.

The corners of bumper on both sides are subsequently defined as the outermost points of contact of the gauge with the outer contour/front fascia of the vehicle as determined in accordance with this procedure. Any points of contact on the top and the bottom edges of the gauge are not taken into account. The external devices for indirect vision and the tyres shall not be considered.

Figure 5A

Corner of bumper example (see paragraph 2.17., note that the corner gauge is to be moved in vertical and horizontal directions to enable contact with the outer contour/front fascia of the vehicle)

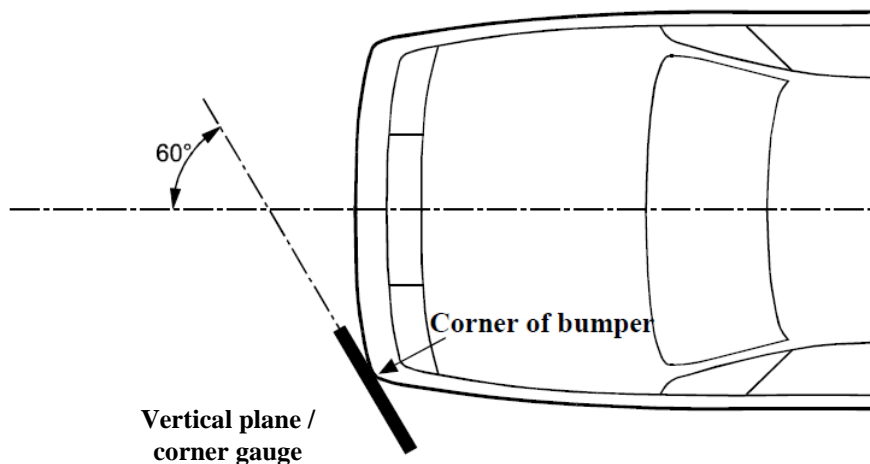
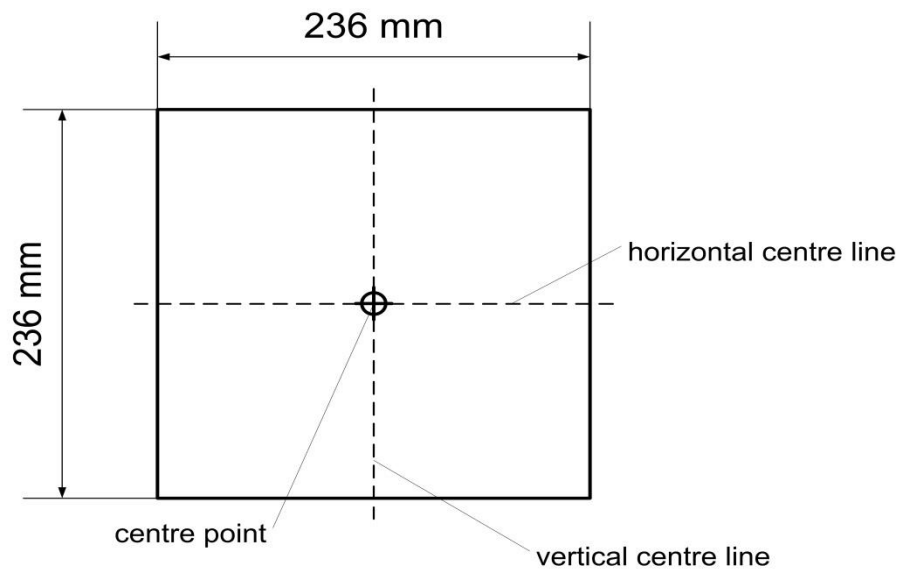

Figure 5B
Corner gauge



The front surface of the corner gauge is flat.

The centre point is the intersection of the vertical and horizontal centre lines on the front surface.

Figure 5C
Determination of the corner of bumper with the corner gauge (shown in random location)

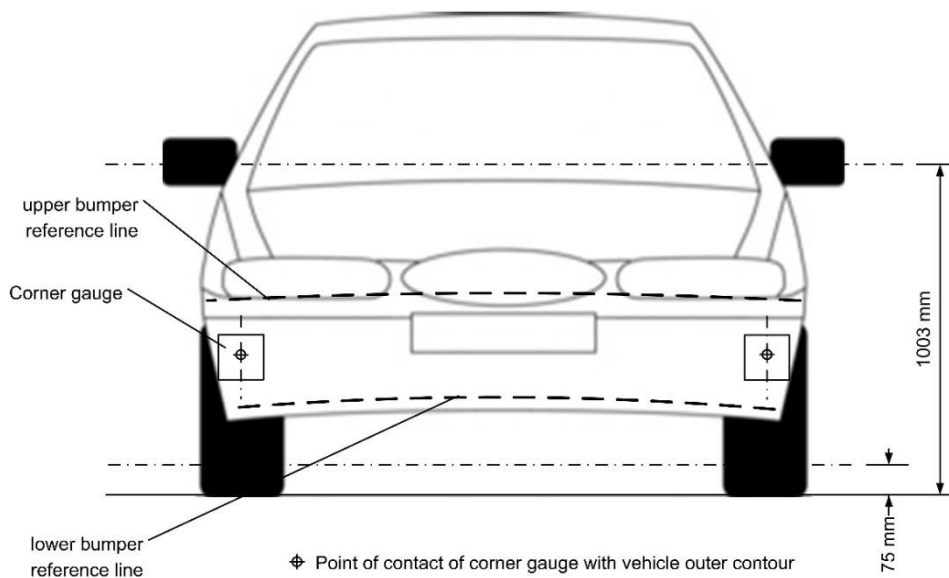
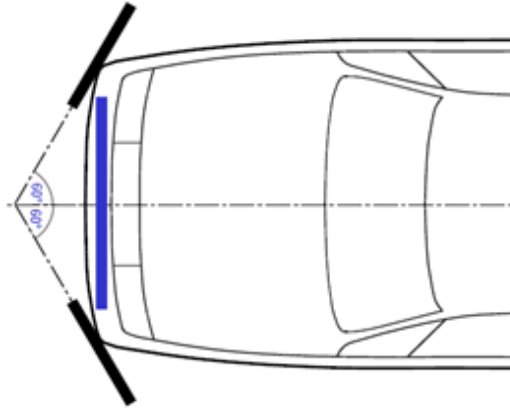

Figure 5D

Determination of bumper test area (note that the corner gauges are to be moved in vertical and horizontal directions to enable contact with the outer contour/front fascia of the vehicle)



- 2.18. "Corner reference point" means the intersection of the bonnet leading edge reference line and of the bonnet side reference line (see Figure 6).

Figure 6

Determination of corner reference point; intersection of the bonnet leading edge reference line and the bonnet side reference line

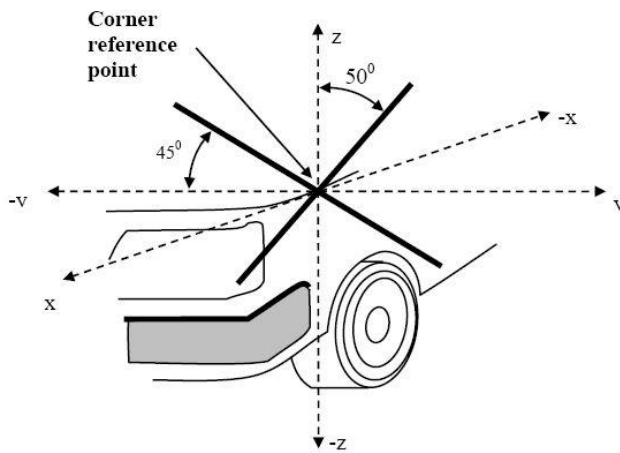

- 2.19. "Driver mass" means the nominal mass of a driver that shall be 75 kg (subdivided into 68 kg occupant mass at the seat and 7 kg luggage mass in accordance with ISO standard 2416–1992).
- 2.20. "Femur" of the lower legform impactor is defined as all components or parts of components (including flesh, skin covering, damper, instrumentation and brackets, pulleys, etc. attached to the impactor for the purpose of launching it) above the level of the centre of the knee.
- 2.21. "Front reference line for child headform" means the geometric trace as described on the vehicle front structure using a WAD1000 line. In the case of vehicles where the wrap around distance to the bonnet leading edge reference

line, is more than 1,000 mm at any point, then the bonnet leading edge reference line will be used as the front reference line for child headform at that point.

- 2.22. "*Front structure*" means all outer structures of the vehicle except the windscreen, the windscreen header, the A-pillars and structures rearward of these. It therefore includes, but is not limited to, the bumper, the bonnet, wings, scuttle, wiper spindles and lower windscreen frame.
- 2.23. "*Ground reference plane*" means a horizontal plane, either real or imaginary, that passes through the lowest points of contact for all tyres of a vehicle while the vehicle is in its normal ride attitude. If the vehicle is resting on the ground, then the ground level and the ground reference plane are one and the same. If the vehicle is raised off the ground such as to allow extra clearance below the bumper, then the ground reference plane is above ground level.
- 2.24. "*Head Injury Criterion (HIC)*" means the calculated result of accelerometer time histories using the following formula:

$$\text{HIC} = \left[\frac{1}{t_2 - t_1} \int_{t_1}^{t_2} a \, dt \right]^{2.5} (t_2 - t_1)$$

Where:

"*a*" is the resultant acceleration measured in units of gravity "g" (1 g = 9.81 m/s²);

"*t*₁" and "*t*₂" are the two time instants (expressed in seconds) during the impact, defining an interval between the beginning and the end of the recording period for which the value of HIC is a maximum (*t*₂ - *t*₁ ≤ 15 ms).

- 2.25. "*Lower bumper height*" means the vertical distance between the ground reference plane and the lower bumper reference line, with the vehicle positioned in its normal ride attitude.
- 2.26. "*Lower bumper reference line*" means the lower limit to significant points of pedestrian contact with the bumper. It is defined as the geometric trace of the lowermost points of contact between a straight edge 700 mm long and the bumper, when the straight edge, held parallel to the vertical longitudinal plane of the vehicle and inclined forwards by 25° from the vertical, is traversed across the front of the vehicle, while maintaining contact with the ground and with the surface of the bumper (see Figure 8).

Figure 7
Lower Bumper Reference Line (LBRL)

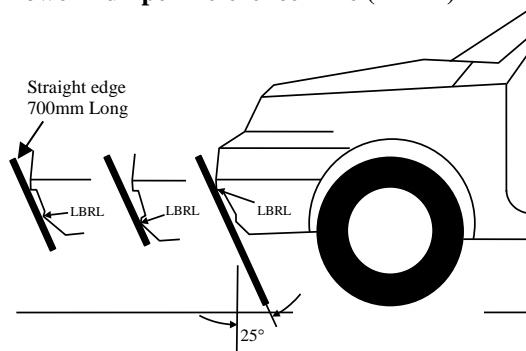

- 2.27. "Mass in running order" means the nominal mass of a vehicle as determined by the sum of unladen vehicle mass and driver's mass.
- 2.28. "Measuring point"
- The measuring point may also be referred to as "test point" or "impact point". In all cases, the result of the test shall be attributed to this point, independent of where first contact occurs.
- 2.28.1. "Measuring point" for the headform test means a point on the vehicle's outer surface selected for assessment. The measuring point is where the headform's profile contacts the vehicle's outer surface cross section in a vertical longitudinal plane through the center of gravity of the headform (see Figure 8A).
- 2.28.2. "Measuring point" for the lower legform to bumper test and the upper legform to bumper test is located in the vertical longitudinal plane through the central axis of the impactor (see Figure 8B).

Figure 8A
Measuring point in the vertical longitudinal plane through the center of the headform impactor (see paragraph 2.28.1.)²

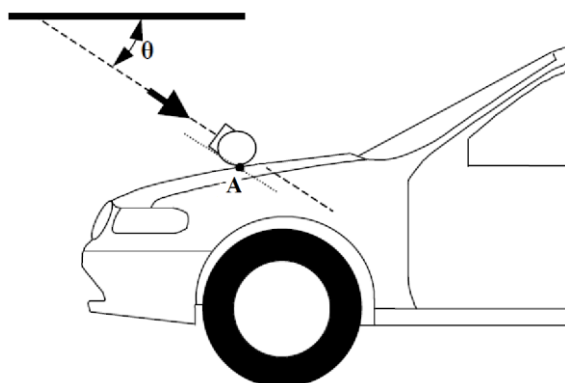

² Remark: due to the spatial geometry of the bonnet top, the first contact may not occur in the same vertical longitudinal or transverse plane which contains measuring point A.

Figure 8B
Measuring point in the vertical longitudinal plane through the central axis of the legform impactor (see paragraph 2.28.2.)

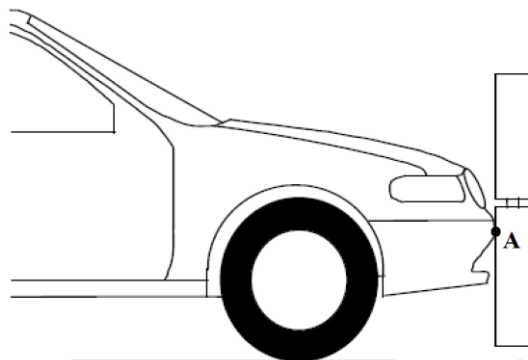

- 2.29. "Normal ride attitude" means the vehicle positioned on a flat horizontal surface with its mass in running order, with the tyres inflated to manufacturer recommended pressures, the front wheels in the straight-ahead position and with a passenger mass placed on the front passenger seat. The front seats are placed at the nominal mid-track position. The suspension shall be set in normal running condition as specified by the manufacturer for a speed of 40 km/h.
- 2.30. "Passenger mass" means the nominal mass of a passenger that shall be 68 kg, with in addition a 7 kg provision for luggage which shall be located in the luggage compartment(s) in accordance with ISO standard 2416-1992.
- 2.31. "Primary reference marks" means holes, surfaces, marks and identification signs on the vehicle body. The type of reference mark used and the vertical (Z) position of each mark relative to the ground shall be specified by the vehicle manufacturer according to the running conditions specified in paragraph 2.27. These marks shall be selected so as to be able to easily check the vehicle front and rear ride heights and vehicle attitude.
- If the primary reference marks are found to be within ± 25 mm of the design position in the vertical (Z) axis, then the design position shall be considered to be the normal ride height. If this condition is met, either the vehicle shall be adjusted to the design position, or all further measurements shall be adjusted, and tests performed, to simulate the vehicle being at the design position.
- 2.32. "Side reference line" means the geometric trace of the highest points of contact between a straight edge 700 mm long and the sides of the vehicle, when the straight edge, held parallel to the transverse vertical plane of the vehicle and inclined inwards by 45° , is traversed down, and maintains contact with the sides of the front structure (see Figure 9).

Figure 9
Side reference line

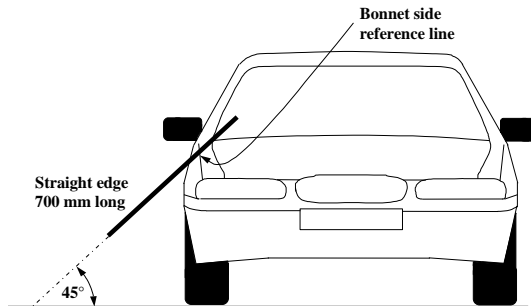

- 2.33. "*Third of the bonnet leading edge*" means the geometric trace between the corner reference points, measured with a flexible tape following the outer contour of the leading edge, divided in three equal parts.
- 2.34. "*Third of the bonnet top*" means the geometric trace of the area between the bonnet side reference lines, measured with a flexible tape following the outer contour of the bonnet top on any transverse section, divided in three equal parts.
- 2.35. "*Third of the bumper*" means the geometric trace between the corners of the bumper, measured with a flexible tape following the outer contour of the bumper, divided in three equal parts.
- 2.36. "*Tibia*" of the lower legform impactor is defined as all components or parts of components (including flesh, skin covering, instrumentation and brackets, pulleys, etc. attached to the impactor for the purpose of launching it) below the level of the centre of the knee. Note that the tibia as defined includes allowances for the mass, etc., of the foot.
- 2.37. "*Unladen vehicle mass*" means the nominal mass of a complete vehicle as determined by the following criteria:
- 2.37.1. Mass of the vehicle with bodywork and all factory fitted equipment, electrical and auxiliary equipment for normal operation of vehicle, including liquids, tools, fire extinguisher, standard spare parts, chocks and spare wheel, if fitted.
- 2.37.2. The fuel tank shall be filled to at least 90 per cent of rated capacity and the other liquid containing systems (except those for used water) to 100 per cent of the capacity specified by the manufacturer
- 2.38. "*Upper bumper reference line*" means a line which identifies the upper limit to significant points of pedestrian contact with the bumper. It is defined as the geometric trace of the upper most points of contact between a straight edge 700 mm long and the bumper, when the straight edge, held parallel to the vertical longitudinal plane and inclined rearwards by 20°, is traversed across the front of the vehicle, while maintaining contact with the ground and with the surface of the bumper (see Figure 10).

Where necessary the straight edge shall be shortened to avoid any contact with structures above the bumper.

Figure 10
Upper Bumper Reference Line (UBRL)

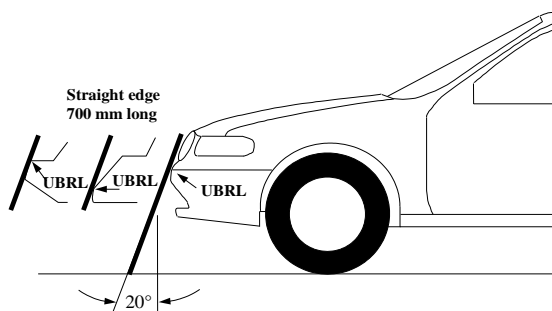

2.39. "Vehicle type with regard to the pedestrian protection requirements" means a category of vehicles which, forward of the A-pillars, do not differ in such essential respects as:

- (a) The structure,
- (b) The main dimensions,
- (c) The materials of the outer surfaces of the vehicle,
- (d) The component arrangement (external or internal),

In so far as they may be considered to have a negative effect on the results of the impact tests prescribed in this Regulation.

2.40. "Vehicles of category M_1 derived from N_1 " means those vehicles of M_1 category which, forward of the A-pillars, have the same general structure and shape as a pre-existing N_1 category vehicle.

2.41. "Vehicles of category N_1 derived from M_1 " means those vehicles of N_1 category which, forward of the A-pillars, have the same general structure and shape as a pre-existing M_1 category vehicle.

2.42. "Windscreen" means the frontal glazing of the vehicle situated between the A-pillars.

2.43. "Wrap Around Distance (WAD)" means the geometric trace described on the outer surface of the vehicle front structure by one end of a flexible tape, when it is held in a vertical longitudinal plane of the vehicle and traversed across the front structure. The tape is held taut throughout the operation with one end held at the same level as the ground reference plane, vertically below the front face of the bumper and the other end held in contact with the front structure (see Figure 11). The vehicle is positioned in the normal ride attitude.

This procedure shall be followed, using alternative tapes of appropriate lengths, to describe wrap around distances of 1,000 mm (WAD1000), of 1,700 mm (WAD1700) and of 2,100 mm (WAD2100).

Figure 11
Wrap around distance measurement

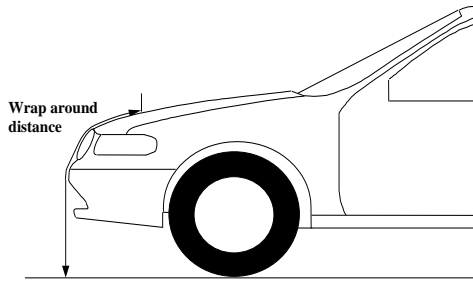

3. Application for approval

- 3.1. The application for approval of a vehicle type with regard to the pedestrian protection requirements shall be submitted by the vehicle manufacturer or by his authorized representative.
- 3.2. It shall be accompanied by the documents mentioned below in triplicate and include the following particulars:
 - 3.2.1. The manufacturer shall submit to the Type Approval Authority the information document, established in accordance with the model set out in Part 1 of Annex 1, including a description of the vehicle type with regard to the items mentioned in paragraph 2.39., together with dimensional drawings. The numbers and/or symbols identifying the vehicle type shall be specified.
- 3.3. A vehicle representative of the vehicle type to be approved shall be submitted to the Technical Service conducting the approval tests.

4. Approval

- 4.1. If the vehicle type submitted for approval pursuant to this Regulation meets the requirements of paragraph 5. below, approval of that vehicle shall be granted.
- 4.2. An approval number shall be assigned to each type approved; its first two digits (at present 02 corresponding to the 02 series of amendments) shall indicate the series of amendments incorporating the most recent major technical amendments made to the Regulation at the time of issue of the approval. The same Contracting Party shall not assign the same number to another vehicle type.
- 4.3. Notice of approval or of refusal or withdrawal of approval pursuant to this Regulation shall be communicated to the Parties to the Agreement which apply this Regulation by means of a form conforming to the model in Annex 1, Part 2 and photographs and/or plans supplied by the applicant being in a format not exceeding A4 (210 x 297 mm), or folded to that format, and on an appropriate scale.
- 4.4. There shall be affixed, conspicuously and in a readily accessible place specified on the approval form, to every vehicle conforming to a vehicle type approved under this Regulation, an international approval mark conforming to the model described in Annex 2, consisting of:

- 4.4.1. A circle surrounding the letter "E" followed by the distinguishing number of the country which has granted approval;³
- 4.4.2. The number of this Regulation, followed by the letter "R", a dash and the approval number to the right of the circle prescribed in paragraph 4.4.1. above.
- 4.5. If the vehicle conforms to a vehicle type approved under one or more other Regulations, annexed to the Agreement, in the country which has granted approval under this Regulation, the symbol prescribed in paragraph 4.4.1. needs not be repeated; in such a case, the Regulation and approval numbers and the additional symbols shall be placed in vertical columns to the right of the symbol prescribed in paragraph 4.4.1. above.
- 4.6. The approval mark shall be clearly legible and be indelible.
- 4.7. The approval mark shall be placed close to or on the vehicle data plate.

5. Specifications

- 5.1. Legform test to bumper:

For vehicles with a lower bumper height at the test position of less than 425 mm the requirements of paragraph 5.1.1. shall be applied.

For vehicles with a lower bumper height at the test position which is greater than, or equal to, 425 mm and less than 500 mm the requirements of either paragraph 5.1.1. or 5.1.2., at the choice of the manufacturer, shall be applied.

For vehicles with a lower bumper height at the test position of greater than, or equal to, 500 mm the requirements of paragraph 5.1.2. shall be applied.
- 5.1.1. Flexible lower legform to bumper:

When tested in accordance with Annex 5, paragraph 1. (Flexible lower legform impactor), the absolute value of the maximum dynamic medial collateral ligament elongation at the knee shall not exceed 22 mm, and the maximum dynamic anterior cruciate ligament and posterior cruciate ligament elongation shall not exceed 13 mm. The absolute value of dynamic bending moments at the tibia shall not exceed 340 Nm. In addition, the manufacturer may nominate bumper test widths up to a maximum of 264 mm in total where the absolute value of the tibia bending moment shall not exceed 380 Nm. A Contracting Party may restrict application of the relaxation zone requirement in its domestic legislation if it decides that such restriction is appropriate.

The flexible lower legform impactor shall be certified pursuant to Annex 6, paragraph 1.
- 5.1.2. Upper legform to bumper

When tested in accordance with Annex 5, paragraph 2. (upper legform to bumper), the instantaneous sum of the impact forces with respect to time shall not exceed 7.5 kN and the bending moment on the test impactor shall not exceed 510 Nm.

³ The distinguishing numbers of the Contracting Parties to the 1958 Agreement are reproduced in Annex 3 to the Consolidated Resolution on the Construction of Vehicles (R.E.3), document ECE/TRANS/WP.29/78/Rev.6 - www.unece.org/trans/main/wp29/wp29wgs/wp29gen/wp29resolutions.html

The upper legform impactor shall be certified pursuant to Annex 6, paragraph 2.

5.2. Headform tests

5.2.1. Child and adult headform tests:

When tested in accordance with Annex 5, paragraphs 3., 4., and 5., the HIC recorded shall not exceed 1,000 over two thirds of the bonnet top test area. The HIC for the remaining areas shall not exceed 1,700 for both headforms.

In case there is only a child headform test area, the HIC recorded shall not exceed 1,000 over two thirds of the test area. For the remaining area the HIC shall not exceed 1,700.

5.2.2. Child headform impact

When tested in accordance with Annex 5, paragraphs 3. and 4., the HIC recorded shall not exceed 1,000 over a minimum of one half of the child headform test area. The HIC for the remaining areas shall not exceed 1,700.

5.2.3. The headform impactors shall be certified pursuant to Annex 6, paragraph 3.

6. Modification of vehicle type and extension of approval

6.1. Every modification of the vehicle type as defined in paragraph 2.37. above shall be notified to the Type Approval Authority which approved the vehicle type. The Authority may then either:

6.1.1. Consider that the modifications made do not have an adverse effect on the conditions of the granting of the approval and grant an extension of approval;

6.1.2. Consider that the modifications made affect the conditions of the granting of the approval and require further tests or additional checks before granting an extension of approval.

6.2. Confirmation or refusal of approval, specifying the alterations, shall be communicated by the procedure specified in paragraph 4.3. above to the Contracting Parties to the Agreement which apply this Regulation.

6.3. The Type Approval Authority shall inform the other Contracting Parties of the extension by means of the communication form conforming to the model of in Annex 1, Part 2 to this Regulation. It shall assign a serial number to each extension, to be known as the extension number.

7. Conformity of production

7.1. Procedures concerning conformity of production shall conform to the general provisions defined in the Agreement, Schedule 1 (E/ECE/TRANS/505/Rev.3), and meet the following requirements:

7.2. A vehicle approved pursuant to this Regulation shall be so manufactured as to conform to the type approved by meeting the requirements of paragraph 5. above;

- 7.3. The Type Approval Authority which has granted approval may at any time verify the conformity of control methods applicable to each production unit. The normal frequency of such inspections shall be once every two years.

8. Penalties for non-conformity of production

- 8.1. The approval granted in respect of a vehicle type pursuant to this Regulation may be withdrawn if the requirements laid down in paragraph 7. above are not complied with.
- 8.2. If a Contracting Party withdraws an approval it had previously granted, it shall forthwith so notify the other Contracting Parties applying this Regulation by sending them a communication form conforming to the model set out in Part 2 of Annex 1 to this Regulation.

9. Production definitively discontinued

If the holder of the approval completely ceases to manufacture a type of vehicle approved in accordance with this Regulation, he shall so inform the Type Approval Authority which granted the approval, which in turn shall forthwith inform the other Contracting Parties to the Agreement applying this Regulation by means of a communication form conforming to the model set out in Part 2 of Annex 1 to this Regulation.

10. Names and addresses of the Technical Services responsible for conducting approval tests and of the Type Approval Authorities

The Contracting Parties to the Agreement applying this Regulation shall communicate to the United Nations Secretariat the names and addresses of the Technical Services responsible for conducting approval tests and of the Type Approval Authorities which grant approval and to which forms certifying approval or extension or refusal or withdrawal of approval are to be sent.

11. Transitional provisions

- 11.1. As from the official date of entry into force of the 02 series of amendments, no Contracting Party applying this Regulation shall refuse to grant or refuse to accept type approvals under this Regulation as amended by the 02 series of amendments.
- 11.2. As from 31 December 2017, Contracting Parties applying this Regulation shall grant type approvals only if the vehicle type to be approved meets the requirements of this Regulation as amended by the 02 series of amendments.
- 11.3. Contracting Parties applying this Regulation shall not refuse to grant extensions of type approvals for existing vehicle types which have been granted according to the original series of this Regulation or to the 01 series of amendments to this Regulation.

- 11.4. Contracting Parties applying this Regulation shall continue to accept type approvals to the original series of this Regulation and to the 01 series of amendments to the Regulation.

Annex 1

Part 1

Model

Information document No ... relating to the type approval of a vehicle with regard to pedestrian protection

The following information, if applicable, shall be supplied in triplicate and include a list of contents. Any drawings shall be supplied in appropriate scale and in sufficient detail on size A4 or on a folder of A4 format. Photographs, if any, shall show sufficient details.

If the systems, components or separate technical units have electronic controls, information concerning their performance shall be supplied.

- 0. General
 - 0.1. Make (trade name of manufacturer):
 - 0.2. Type:
 - 0.2.1. Commercial name(s) (if available):
 - 0.3. Means of identification of type, if marked on the vehicle:^{1,2}
 - 0.3.1. Location of that marking:
 - 0.4. Category of vehicle:³
 - 0.5. Name and address of manufacturer:
 - 0.6. Name(s) and address(es) of assembly plant(s):
 - 0.7. Name and address of the manufacturer's representative (if any):
- 1. General construction characteristics of the vehicle
 - 1.1. Photographs and/or drawings of a representative vehicle:
 - 1.6. Position and arrangement of the engine:
- 9. Bodywork
 - 9.1. Type of bodywork:

¹ Delete where not applicable (there are cases where nothing needs to be deleted when more than one entry is applicable).

² If means of identification of type contains characters not relevant to describe the vehicle type covered by this information document, such characters shall be represented in the documentation by the symbol "?" (e.g. ABC??123??).

³ As defined in the Consolidated Resolution on the Construction of Vehicles (R.E.3.), document ECE/TRANS/WP.29/78/Rev.6, para. 2. - www.unece.org/trans/main/wp29/wp29wgs/wp29gen/wp29resolutions.html

- 9.2. Materials used and methods of construction:
- 9.23. Pedestrian protection
- 9.23.1. A detailed description, including photographs and/or drawings, of the vehicle with respect to the structure, the dimensions, the relevant reference lines and the constituent materials of the frontal part of the vehicle (interior and exterior) shall be provided. This description shall include detail of any active protection system installed.

Annex 1

Part 2

Communication

(Maximum format: A4 (210 x 297 mm))



issued by: Name of administration:
.....
.....
.....

- Concerning:²
- Approval granted
 - Approval extended
 - Approval refused
 - Approval withdrawn
 - Production definitively discontinued

of a type of vehicle with regard to the pedestrian safety performance pursuant to UN Regulation No. 127

Approval No.: Extension No.:

1. Trademark:
2. Type and trade names:
3. Name and address of manufacturer:
4. If applicable, name and address of manufacturer's representative:
5. Brief description of vehicle:
6. Date of submission of vehicle for approval:
7. Technical Service performing the approval tests:
8. Date of report issued by that Service:
9. Number of report issued by that Service:
10. Approval with regard to the pedestrian safety performance is granted/refused:²
11. Place:
12. Date:
13. Signature:

¹ Distinguishing number of the country which has granted/extended/refused/withdrawn an approval (see approval provisions in the Regulation).

² Delete what does not apply.

14. Annexed to this communication are the following documents, bearing the approval number indicated above:
- Dimensional drawings
- Exploded view or photograph of the vehicle
15. Any remarks:.....

Annex 2

Arrangements of approval marks

(See paragraphs 4.4. to 4.4.2. of this Regulation)

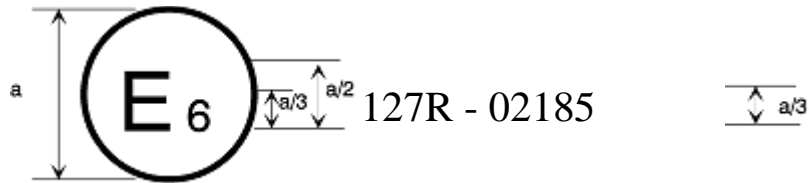

a = 8 mm min

The above approval mark affixed to a vehicle shows that the vehicle type concerned has been approved in Belgium (E 6) with regard to its pedestrian safety performance pursuant to UN Regulation No. 127. The first two digits of the approval number indicate that the approval was granted in accordance with the requirements of UN Regulation No. 127 as amended by the 02 series of amendments.

Annex 3

General test conditions

1. Temperature and humidity
 - 1.1. At the time of testing, the test facility and the vehicle or sub-system shall have a relative humidity of 40 per cent \pm 30 per cent and stabilized temperature of $20\text{ }^{\circ}\text{C} \pm 4\text{ }^{\circ}\text{C}$.
2. Impact test site
 - 2.1. The test site shall consist of a flat, smooth and hard surface with a slope not exceeding 1 per cent.
3. Preparation of the vehicle
 - 3.1. Either a complete vehicle, or a cut-body, adjusted to the following conditions shall be used for the test.
 - 3.1.1. The vehicle shall be in its normal ride attitude, and shall be either securely mounted on raised supports or at rest on a flat horizontal surface with the parking brake applied.
 - 3.1.2. The cut-body shall include, in the test, all parts of the vehicle front structure, all under-bonnet components and all components behind the windscreen that may be involved in a frontal impact with a vulnerable road user, to demonstrate the performance and interactions of all the contributory vehicle components. The cut-body shall be securely mounted in the normal vehicle ride attitude.
 - 3.2. All devices designed to protect vulnerable road users when impacted by the vehicle shall be correctly activated before and/or be active during the relevant test. It shall be the responsibility of the manufacturer to show that any devices will act as intended in a pedestrian impact.
 - 3.3. For vehicle components which could change shape or position, other than active devices to protect pedestrians, and which have more than one fixed shape or position shall require the vehicle to comply with the components in each fixed shape or position.

Annex 4

Test impactor specifications

1. Flexible lower legform impactor
 - 1.1. The flexible lower legform impactor shall consist of flesh and skin, flexible long bone segments (representing femur and tibia), and a knee joint as shown in Figure 1. The assembled impactor shall have a total mass of $13.2 \text{ kg} \pm 0.4 \text{ kg}$. The dimensions of the fully assembled impactor shall be as defined in Figure 1.

Brackets, pulleys, protectors, connection parts, etc. attached to the impactor for the purposes of launching and/or protection may extend beyond the dimensions and tolerances shown in Figure 1 and Figures 2(a) and (b).
 - 1.2. The cross-sectional shape of the femur main body segments, the tibia main body segments and their impact faces shall be as defined in Figure 2(a).
 - 1.3. The cross-sectional shape of the knee joint and its impact face shall be as defined in Figure 2(b).
 - 1.4. The masses of the femur and the tibia without the flesh and skin, including the connection parts to the knee joint, shall be $2.46 \text{ kg} \pm 0.12 \text{ kg}$ and $2.64 \text{ kg} \pm 0.13 \text{ kg}$ respectively. The mass of the knee joint without the flesh and skin shall be $4.28 \text{ kg} \pm 0.21 \text{ kg}$. The assembled mass of the femur, the knee joint and the tibia without the flesh and skin shall be $9.38 \text{ kg} \pm 0.3 \text{ kg}$.

The centres of gravity of the femur and tibia without the flesh and skin, including the connection parts to the knee joint, shall be as defined in Figure 1. The centre of gravity of the knee joint shall be as defined in Figure 1.

The moment of inertia of the femur and the tibia without the flesh and skin, including the connection parts inserted to the knee joint, about the X-axis through the respective centre of gravity shall be $0.0325 \text{ kgm}^2 \pm 0.0016 \text{ kgm}^2$ and $0.0467 \text{ kgm}^2 \pm 0.0023 \text{ kgm}^2$ respectively. The moment of inertia of the knee joint about the X-axis through the respective centre of gravity shall be $0.0180 \text{ kgm}^2 \pm 0.0009 \text{ kgm}^2$.
2. Lower legform instrumentation
 - 2.1. Four transducers shall be installed in the tibia to measure bending moments at the locations within the tibia. Three transducers shall be installed in the femur to measure bending moments applied to the femur. The sensing locations of each of the transducers are as defined in Figure 2. The measurement axis of each transducer shall be the X-axis of the impactor.
 - 2.2. Three transducers shall be installed in the knee joint to measure elongations of the Medial Collateral Ligament (MCL), Anterior Cruciate Ligament (ACL), and Posterior Cruciate Ligament (PCL). The measurement locations of each transducer are shown in Figure 3. The measurement locations shall be within $\pm 4 \text{ mm}$ along the X-axis from the knee joint centre.
 - 2.3. The instrumentation response value Channel Frequency Class (CFC), as defined in ISO 6487:2002, shall be 180 for all transducers. The Channel

Amplitude Class (CAC) response values, as defined in ISO 6487:2002, shall be 30 mm for the knee ligament elongations and 400 Nm for the tibia and femur bending moments. This does not require that the impactor itself be able to physically elongate or bend until these values.

- 2.4. The determination of all flexible lower legform impactor peak tibia bending moments and ligament elongations shall be limited to the assessment interval (AI) as defined in paragraph 2.2. of this Regulation.

Figure 1

Flexible lower legform impactor

Dimensions and centre of gravity locations of femur, knee joint and tibia (Side view)

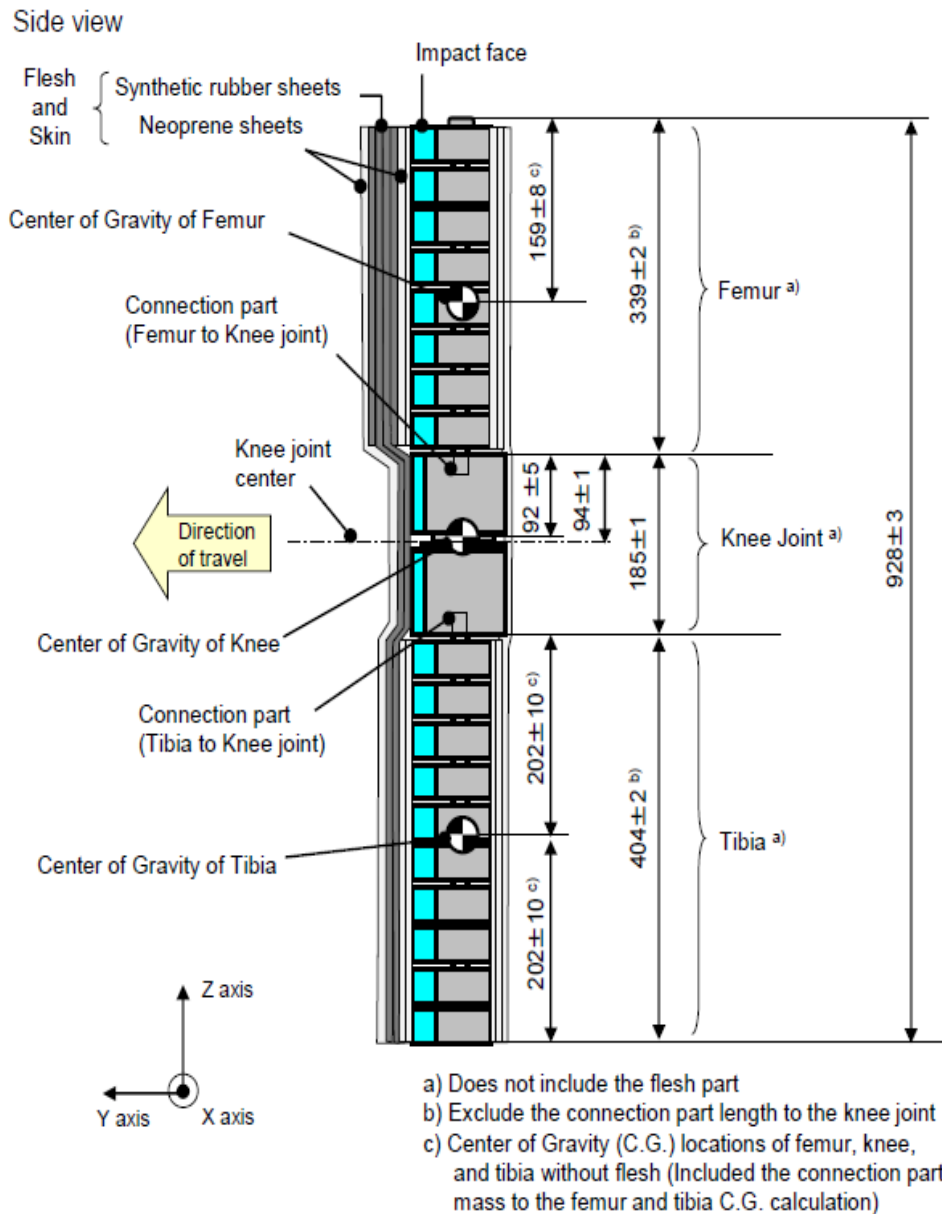

Figure 2
Flexible lower legform impactor schematic plan views of femur, tibia, and knee dimensions (top view)

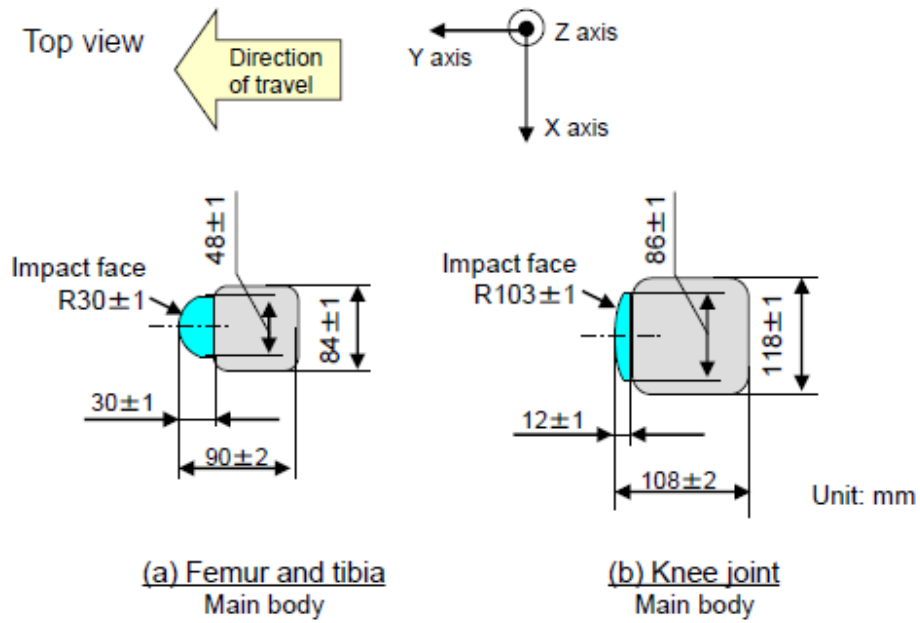
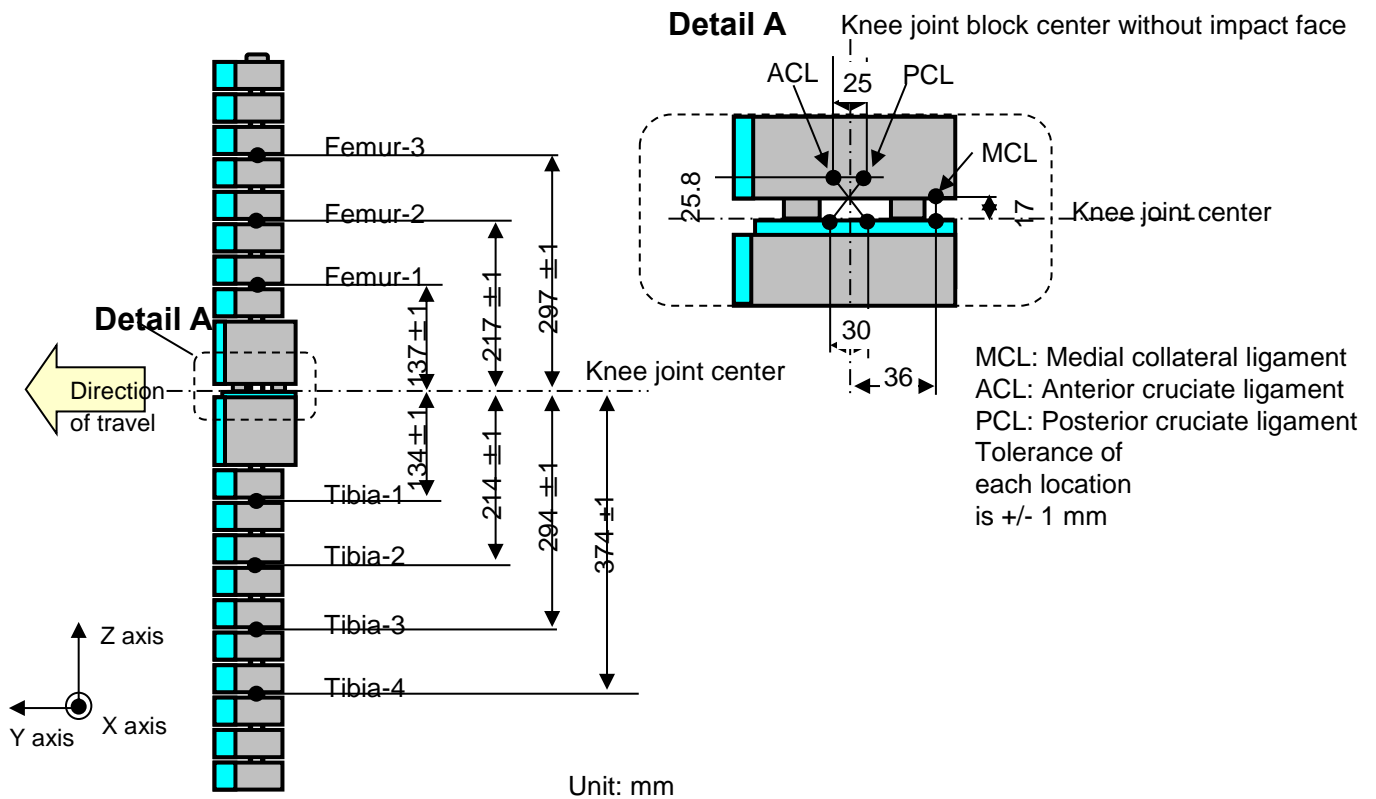

Figure 3
Flexible lower legform impactor instrument locations



3. Upper legform impactor
 - 3.1. The upper legform impactor shall be rigid, foam covered at the impact side, and 350 mm ± 5 mm long (see Figure 4).
 - 3.2. The total mass of the upper legform impactor including those propulsion and guidance components which are effectively part of the impactor during the impact shall be 9.5 kg ± 0.1 kg.
 - 3.3. The total mass of the front member and other components in front of the load transducer assemblies, together with those parts of the load transducer assemblies in front of the active elements, but excluding the foam and skin, shall be 1.95 kg ± 0.05 kg.
 - 3.4. The upper legform impactor for the bumper test shall be mounted to the propulsion system by a torque limiting joint and be insensitive to off-axis loading. The impactor shall move only in the specified direction of impact when in contact with the vehicle and shall be prevented from motion in other directions including rotation about any axis.
 - 3.5. The torque limiting joint shall be set so that the longitudinal axis of the front member is vertical at the time of impact with a tolerance of ±2°, with the joint friction torque set to 675 Nm ± 25 Nm.

- 3.6. The centre of gravity of those parts of the impactor which are effectively forward of the torque limiting joint, including any weights fitted, shall lie on the longitudinal centre line of the impactor, with a tolerance of ± 10 mm.
- 3.7. The length between the load transducer centre lines shall be $310 \text{ mm} \pm 1 \text{ mm}$ and the front member diameter shall be $50 \text{ mm} \pm 1 \text{ mm}$.
- 4. Upper legform instrumentation
 - 4.1. The front member shall be strain gauged to measure bending moments in three positions, as shown in Figure 4, each using a separate channel. The strain gauges are located on the impactor on the back of the front member. The two outer strain gauges are located $50 \text{ mm} \pm 1 \text{ mm}$ from the impactor's symmetrical axis. The middle strain gauge is located on the symmetrical axis with a ± 1 mm tolerance.
 - 4.2. Two load transducers shall be fitted to measure individually the forces applied at either end of the upper legform impactor, plus strain gauges measuring bending moments at the centre of the upper legform impactor and at positions 50 mm either side of the centre line (see Figure 4).
 - 4.3. The instrumentation response value CFC, as defined in ISO 6487:2002, shall be 180 for all transducers. The CAC response values, as defined in ISO 6487:2002, shall be 10 kN for the force transducers and $1,000 \text{ Nm}$ for the bending moment measurements.

Figure 4
 Upper legform impactor

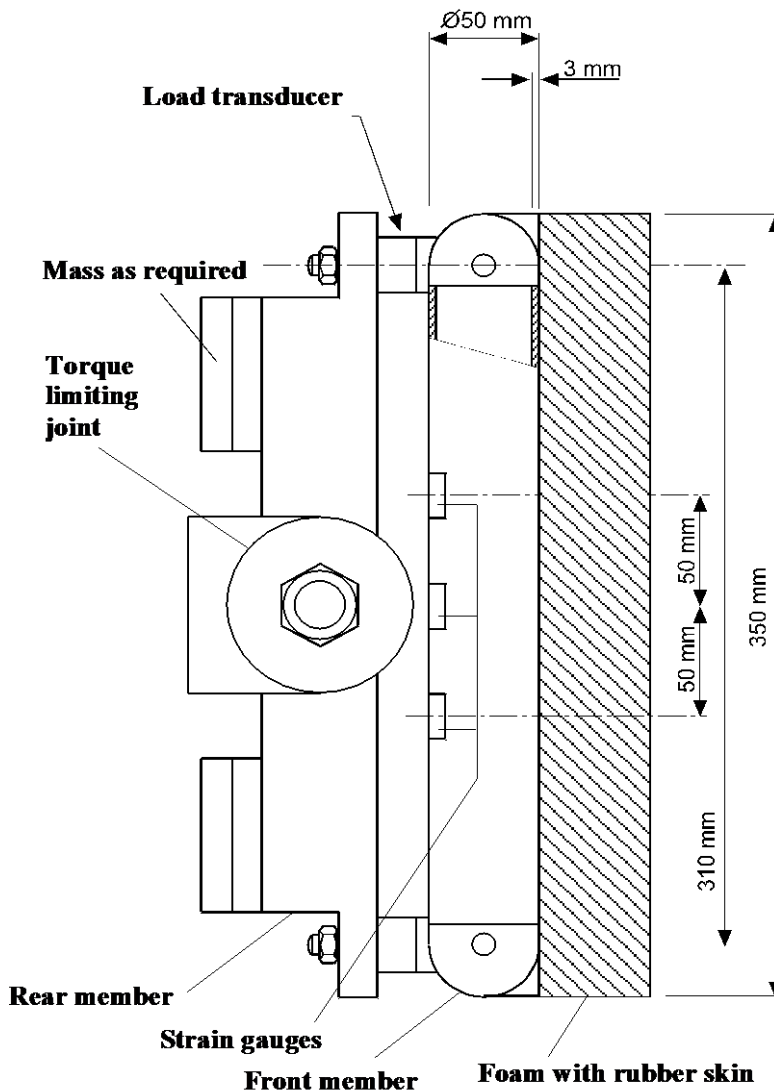

5. Child and adult headform impactors
 - 5.1. Child headform impactor (see Figure 5)
 - 5.1.1. The child headform impactor shall be made of aluminium, be of homogenous construction and be of spherical shape. The overall diameter shall be $165 \text{ mm} \pm 1 \text{ mm}$. The mass shall be $3.5 \text{ kg} \pm 0.07 \text{ kg}$. The moment of inertia about an axis through the centre of gravity and perpendicular to the direction of impact shall be within the range of 0.008 to 0.012 kgm^2 . The centre of gravity of the headform impactor including instrumentation shall be located in the geometric centre of the sphere with a tolerance of $\pm 2 \text{ mm}$.

The sphere shall be covered with a $14 \text{ mm} \pm 0.5 \text{ mm}$ thick synthetic skin, which shall cover at least half of the sphere.
 - 5.1.2. The first natural frequency of the child headform impactor shall be over $5,000 \text{ Hz}$.

- 5.2. Child headform instrumentation
- 5.2.1. A recess in the sphere shall allow for mounting one triaxial or three uniaxial accelerometers within ± 10 mm seismic mass location tolerance from the centre of the sphere for the measurement axis, and ± 1 mm seismic mass location tolerance from the centre of the sphere for the perpendicular direction to the measurement axis.
- 5.2.2. If three uniaxial accelerometers are used, one of the accelerometers shall have its sensitive axis perpendicular to the mounting face A (see Figure 5) and its seismic mass shall be positioned within a cylindrical tolerance field of 1 mm radius and 20 mm length. The centre line of the tolerance field shall run perpendicular to the mounting face and its mid-point shall coincide with the centre of the sphere of the headform impactor.
- 5.2.3. The remaining accelerometers shall have their sensitive axes perpendicular to each other and parallel to the mounting face A and their seismic mass shall be positioned within a spherical tolerance field of 10 mm radius. The centre of the tolerance field shall coincide with the centre of the sphere of the headform impactor.
- 5.2.4. The instrumentation response value CFC, as defined in ISO 6487:2002, shall be 1,000. The CAC response value, as defined in ISO 6487:2002, shall be 500 g for the acceleration.

Figure 5
Child headform impactor

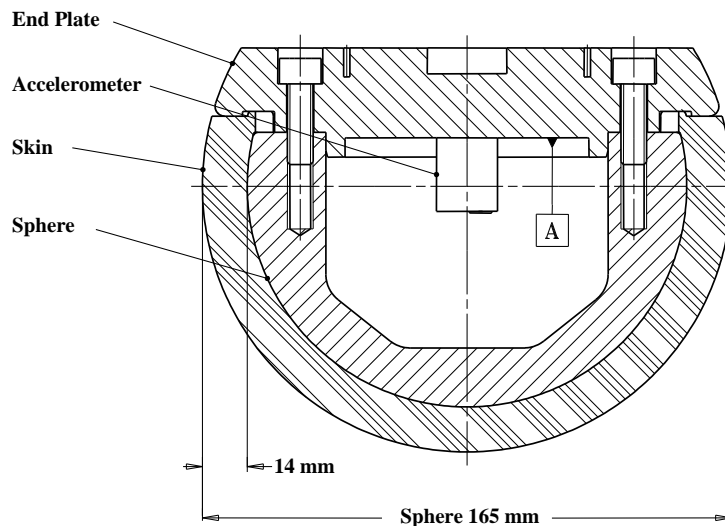

- 5.3. Adult headform impactor (see Figure 6)
- 5.3.1. The adult headform impactor shall be made of aluminium, be of homogenous construction and be of spherical shape. The overall diameter is $165 \text{ mm} \pm 1 \text{ mm}$ as shown in Figure 6. The mass shall be $4.5 \text{ kg} \pm 0.1 \text{ kg}$. The moment of inertia about an axis through the centre of gravity and perpendicular to the direction of impact shall be within the range of 0.010 to 0.013 kgm^2 . The centre of

gravity of the headform impactor including instrumentation shall be located in the geometric centre of the sphere with a tolerance of ± 5 mm.

The sphere shall be covered with a $14 \text{ mm} \pm 0.5 \text{ mm}$ thick synthetic skin, which shall cover at least half of the sphere.

Figure 6
Adult headform impactor

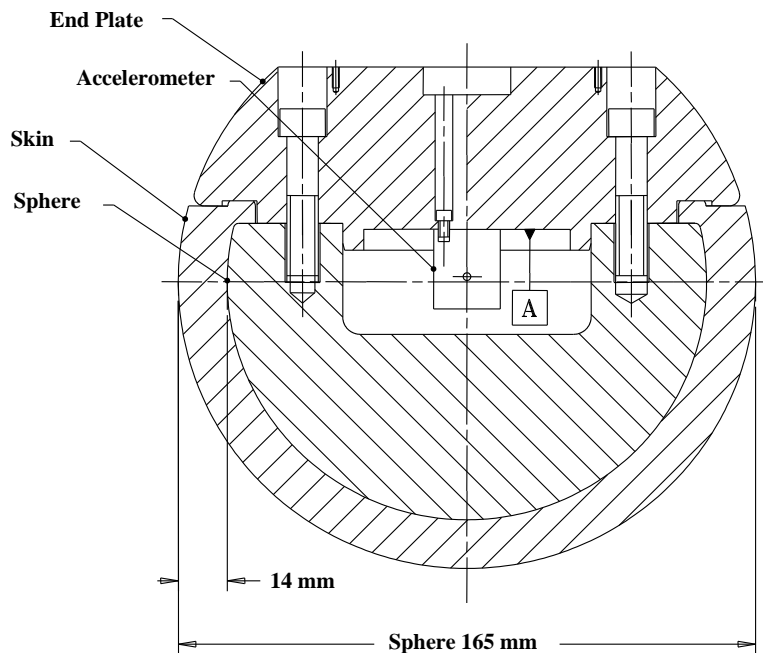

- 5.3.2. The first natural frequency of the headform impactor shall be over 5,000 Hz.
- 5.4. Adult headform instrumentation
- 5.4.1. A recess in the sphere shall allow for mounting one triaxial or three uniaxial accelerometers within ± 10 mm seismic mass location tolerance from the centre of the sphere for the measurement axis, and ± 1 mm seismic mass location tolerance from the centre of the sphere for the perpendicular direction to the measurement axis.
- 5.4.2. If three uniaxial accelerometers are used, one of the accelerometers shall have its sensitive axis perpendicular to the mounting face A (see Figure 6) and its seismic mass shall be positioned within a cylindrical tolerance field of 1 mm radius and 20 mm length. The centre line of the tolerance field shall run perpendicular to the mounting face and its mid-point shall coincide with the centre of the sphere of the headform impactor.
- 5.4.3. The remaining accelerometers shall have their sensitive axes perpendicular to each other and parallel to the mounting face A and their seismic mass shall be positioned within a spherical tolerance field of 10 mm radius. The centre of the tolerance field shall coincide with the centre of the sphere of the headform impactor.

- 5.4.4. The instrumentation response value CFC, as defined in ISO 6487:2002, shall be 1,000. The CAC response value, as defined in ISO 6487:2002, shall be 500 g for the acceleration.
- 5.5. Rear face of the child and adult headform impactors
- A rear flat face shall be provided on the outer surface of the headform impactors which is perpendicular to the direction of travel, and typically perpendicular to the axis of one of the accelerometers as well as being a flat plate capable of providing for access to the accelerometers and an attachment point for the propulsion system.

Annex 5

Test procedures

1. Flexible lower legform impactor
 - 1.1. For each test the impactor (femur, knee joint and tibia) shall be covered by flesh and skin composed of synthetic rubber sheets (R1, R2) and neoprene sheets (N1F, N2F, N1T, N2T, N3) as shown in Figure 1. The size of the sheets shall be within the requirements described in Figure 1. The sheets are required to have compression characteristics as shown in Figure 2. The compression characteristics shall be checked using material from the same batch as the sheets used for the impactor flesh and skin.
 - 1.2. All impactor components shall be stored for a sufficient period of time in a controlled storage area with a stabilized temperature of $20\text{ }^{\circ}\text{C} \pm 4\text{ }^{\circ}\text{C}$ prior to impactor removal for testing. After removal from the storage the impactor shall not be subjected to conditions other than those pertaining in the test area as defined in Annex 3, paragraph 1.1.
 - 1.3. Each test shall be completed within two hours of when the impactor to be used is removed from the controlled storage area.
 - 1.4. The selected measuring points shall be in the bumper test area as defined in paragraph 2.14. of this Regulation.
 - 1.5. A minimum of three lower legform to bumper tests shall be carried out, one each to the middle and the outer thirds of the bumper test area at positions judged to be the most likely to cause injury. Tests shall be to different types of structure, where they vary throughout the area to be assessed. The selected test points shall be a minimum of 84 mm apart as measured horizontally and perpendicular to the longitudinal median plane of the vehicle. The positions tested by the laboratories shall be indicated in the test report.
 - 1.6. The direction of the impact velocity vector shall be in the horizontal plane and parallel to the longitudinal vertical plane of the vehicle. The tolerance for the direction of the velocity vector in the horizontal plane and in the longitudinal plane shall be $\pm 2^{\circ}$ at the time of first contact. The axis of the impactor shall be perpendicular to the horizontal plane with a roll and pitch angle tolerance of $\pm 2^{\circ}$ in the lateral and longitudinal plane. The horizontal, longitudinal and lateral planes are orthogonal to each other (see Figure 3).
 - 1.7. The bottom of the impactor (without parts needed for the purposes of launching and/or protection) shall be at 75 mm above ground reference plane at the time of first contact with the bumper (see Figure 4), with a ± 10 mm tolerance. When setting the height of the propulsion system, an allowance shall be made for the influence of gravity during the period of free flight of the impactor.
 - 1.8. The lower legform impactor for the bumper tests shall be in "free flight" at the moment of impact. The impactor shall be released to free flight at such a distance from the vehicle that the test results are not influenced by contact of the impactor with the propulsion system during rebound of the impactor.

- The impactor may be propelled by any means that can be shown to meet the requirements of the test.
- 1.9. At the time of first contact the impactor shall have the intended orientation about its vertical axis, for the correct operation of its knee joint, with a yaw angle tolerance of $\pm 5^\circ$ (see Figure 3).
 - 1.10. For the lower legform testing, a horizontal and vertical impact tolerance of ± 10 mm shall apply. The test laboratory may verify at a sufficient number of measuring points that this condition can be met and the tests are thus being conducted with the necessary accuracy.
 - 1.11. During contact between the impactor and the vehicle, the impactor shall not contact the ground or any object which is not part of the vehicle.
 - 1.12. The impact velocity of the impactor when striking the bumper shall be $11.1 \text{ m/s} \pm 0.2 \text{ m/s}$. The effect of gravity shall be taken into account when the impact velocity is obtained from measurements taken before the time of first contact.
 - 1.13. The tibia bending moments shall not exceed $\pm 15 \text{ Nm}$ within an evaluation interval of 30 ms immediately prior to impact.
 - 1.14. The offset compensation shall be done with the flexible lower legform impactor in resting position prior to the test/acceleration phase.

Figure 1
Flexible lower legform impactor: Flesh and skin dimensions

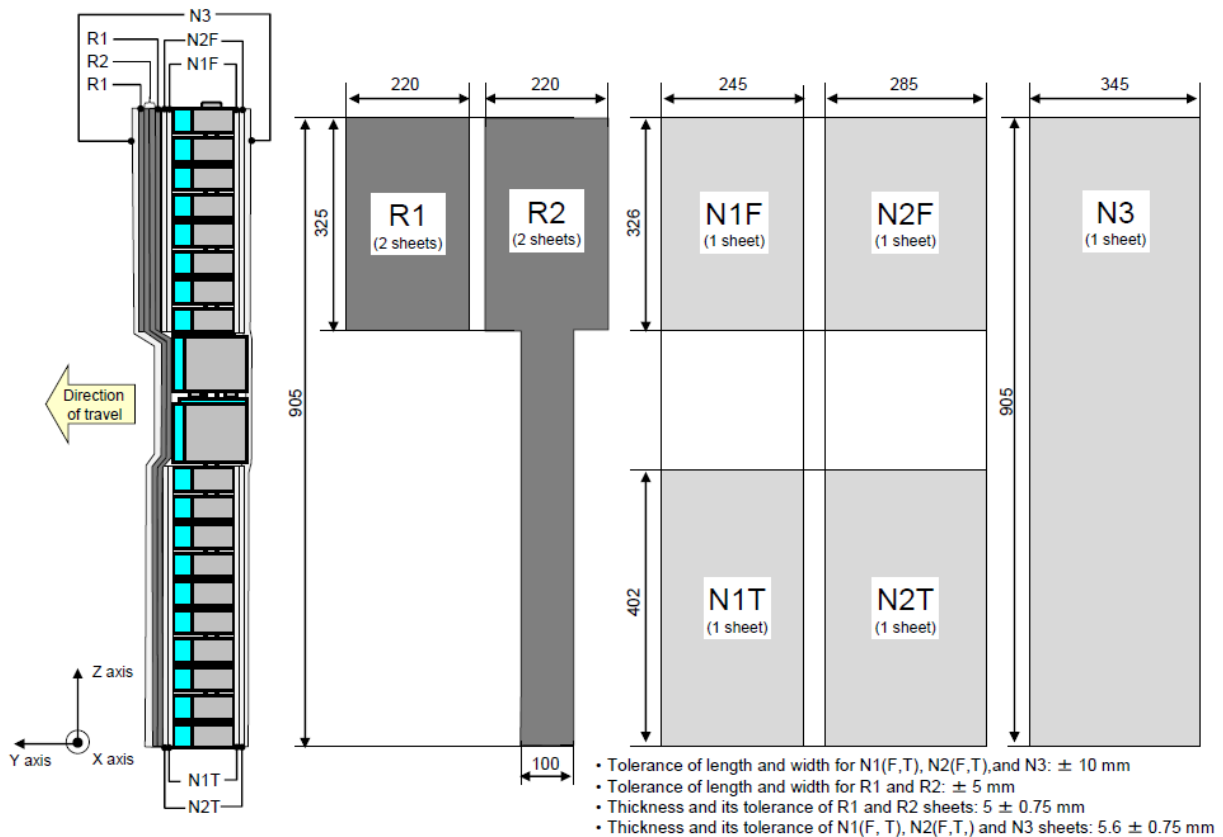
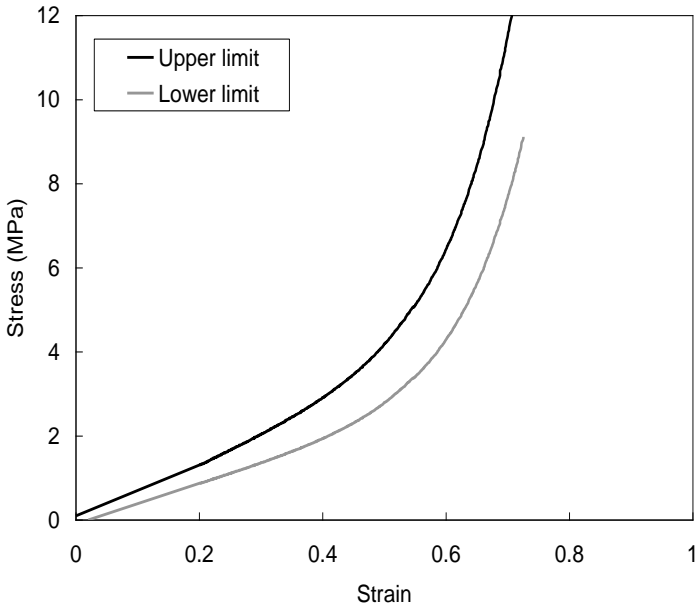

Figure 2
Flexible lower legform impactor: Flesh and skin compression characteristics

(a) Synthetic rubber sheets



(b) Neoprene sheets

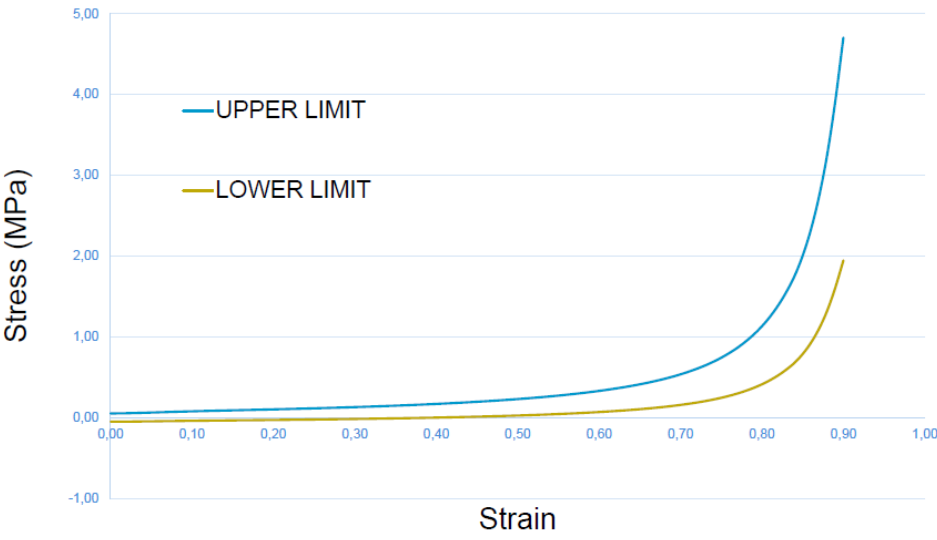

Figure 3
Tolerances of angles for the flexible lower legform impactor at the time of the first impact

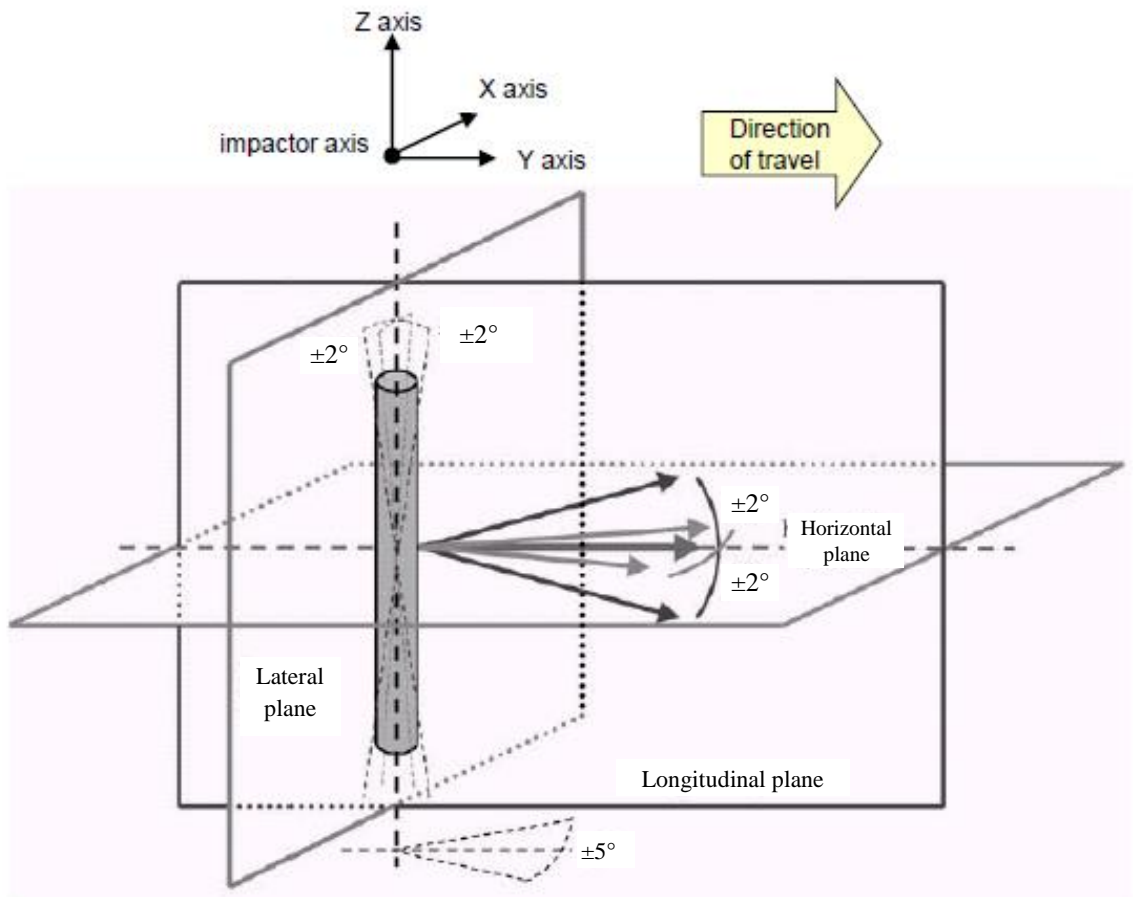
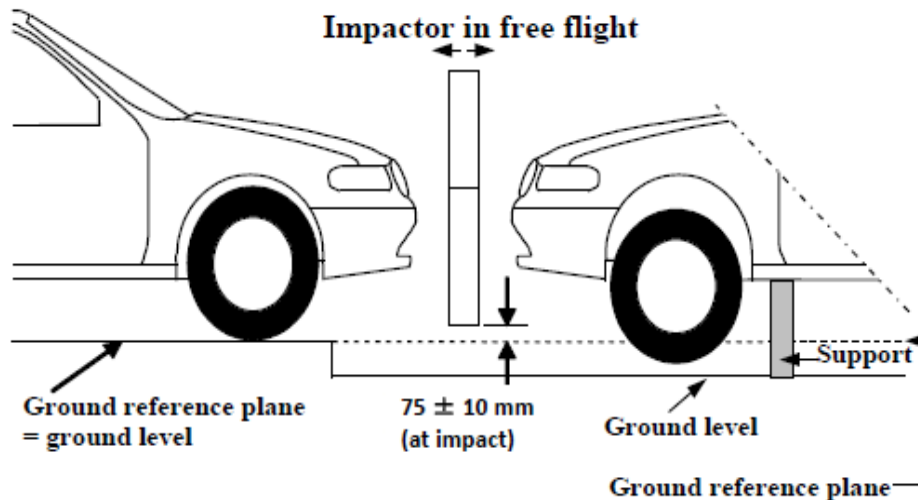

Figure 4
Flexible Lower legform impactor to bumper tests for complete vehicle in normal ride attitude (left) and for cut-body mounted on supports (right)



2. Upper legform to bumper
- 2.1. For each test the foam flesh shall be two new sheets of 25 mm thick foam type CF-45 or equivalent, which shall be cut from the sheet of material used for the dynamic certification test. The skin shall be a 1.5 mm thick fibre reinforced rubber sheet. The mass of the foam and the rubber skin together shall be 0.6 kg \pm 0.1 kg (this excludes any reinforcement, mountings, etc. which are used to attach the rear edges of the rubber skin to the rear member). The foam and rubber skin shall be folded back towards the rear, with the rubber skin attached via spacers to the rear member so that the sides of the rubber skin are held parallel. The foam shall be of such a size and shape that an adequate gap is maintained between the foam and components behind the front member, to avoid significant load paths between the foam and these components.
- 2.2. The test impactor or at least the foam flesh shall be stored during a period of at least four hours in a controlled storage area with a stabilized humidity of 35 per cent \pm 15 per cent and a stabilized temperature of 20 °C \pm 4 °C prior to impactor removal for test. After removal from the storage the impactor shall not be subjected to conditions other than those pertaining in the test area.
- 2.3. Each test shall be completed within two hours of when the impactor to be used is removed from the controlled storage area.
- 2.4. The selected measuring points shall be in the bumper test area as defined in paragraph 2.14. of this Regulation.
- 2.5. A minimum of three upper legform to bumper tests shall be carried out, one each to the middle and the outer thirds of the bumper test area at positions judged to be the most likely to cause injury. Tests shall be to different types of structure, where they vary throughout the area to be assessed. The selected measuring points shall be a minimum of 84 mm apart as measured horizontally and perpendicular to the longitudinal median plane of the vehicle. The positions tested by the laboratories shall be indicated in the test report.

- 2.6. The direction of impact shall be parallel to the longitudinal axis of the vehicle, with the axis of the upper legform vertical at the time of first contact. The tolerance to this direction is $\pm 2^\circ$.
- At the time of first contact the impactor centre line shall be vertically midway between the upper bumper reference line and the lower bumper reference line with a ± 10 mm tolerance and the impactor vertical centre line shall be positioned laterally with the selected impact location with a tolerance of ± 10 mm. The test laboratory may verify at a sufficient number of measuring points that this condition can be met and the tests are thus being conducted with the necessary accuracy.
- 2.7. The impact velocity of the upper legform impactor when striking the bumper shall be $11.1 \text{ m/s} \pm 0.2 \text{ m/s}$.
3. Child and adult headform test procedures – Common test specifications
- 3.1. Propulsion of the headform impactors
- 3.1.1. The headform impactors shall be in "free flight" at the moment of impact, at the required impact velocity (as specified in paragraphs 4.6. and 5.6. below) and the required direction of impact (as specified in paragraphs 4.7. and 5.7. below).
- 3.1.2. The impactors shall be released to "free flight" at such a distance from the vehicle that the test results are not influenced by contact of the impactor with the propulsion system during rebound of the impactor.
- 3.2. Measurement of impact velocity
- 3.2.1. The velocity of the headform impactor shall be measured at some point during the free flight before impact, in accordance with the method specified in ISO 3784:1976. The measured velocity shall be adjusted considering all factors which may affect the impactor between the point of measurement and the point of impact, in order to determine the velocity of the impactor at the time of impact. The angle of the velocity vector at the time of impact shall be calculated or measured.
- 3.3. Recording
- 3.3.1. The acceleration time histories shall be recorded, and HIC shall be calculated. The measuring point on the front structure of the vehicle shall be recorded. Recording of test results shall be in accordance with ISO 6487:2002.
- 3.4. Splitting of headform test zones
- 3.4.1. The manufacturer shall identify the zones of the bonnet top test area where the HIC shall not exceed 1,000 (HIC1000 zone) or 1,700 (HIC1700 zone) (see Figure 5).

Figure 5
Example of marking of HIC1000 zone and HIC1700 zone

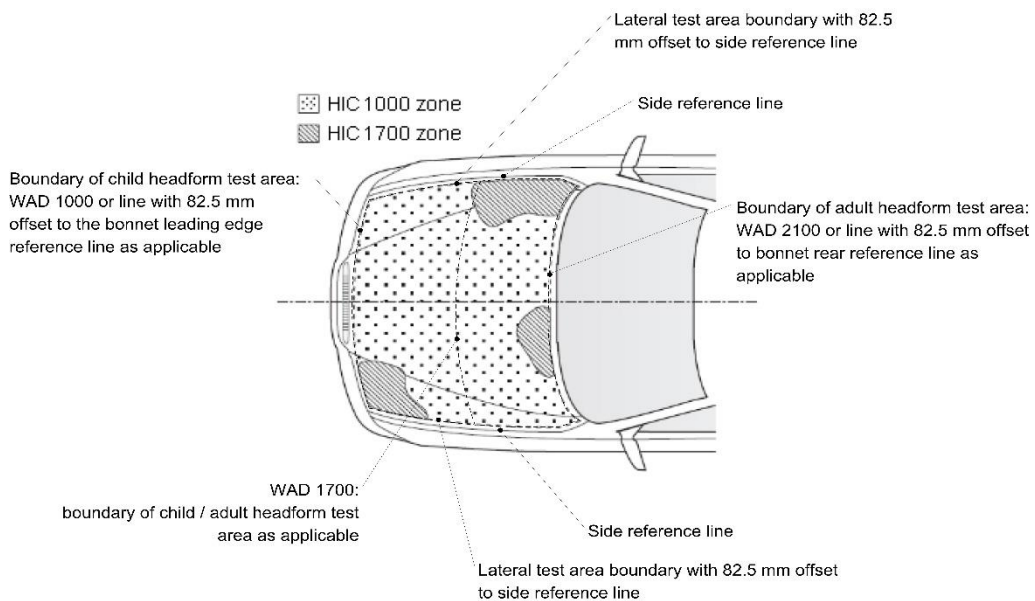

- 3.4.2. Marking of the "bonnet top" test area as well as "HIC1000 zone" and "HIC1700 zone" will be based on a drawing supplied by the manufacturer, when viewed from a horizontal plane above the vehicle that is parallel to the vehicle horizontal zero plane. A sufficient number of x and y co-ordinates shall be supplied by the manufacturer to mark up the areas on the actual vehicle while considering the vehicle outer contour in the z direction.
- 3.4.3. The areas of "HIC1000 zone" and "HIC1700 zone" may consist of several parts, with the number of these parts not being limited. The determination of the impacted zone is done by the measuring point.
- 3.4.4. The calculation of the surface of the bonnet top test area as well as the surface areas of "HIC1000 zone" and "HIC1700 zone" shall be done on the basis of a projected bonnet when viewed from a horizontal plane parallel to the horizontal zero plane above the vehicle, on the basis of the drawing data supplied by the manufacturer.
- 3.5. **Measuring points – Particular specifications**
- Notwithstanding the provisions of paragraphs 4.2. and 5.2. below, if a number of measuring points have been selected in order of potential to cause injury and the test area remaining is too small to select another measuring point while maintaining the minimum spacing between points, then less than nine tests for each impactor may be performed. The positions tested by the laboratories shall be indicated in the test report. However, the technical services conducting the tests shall perform as many tests as necessary to guarantee the compliance of the vehicle with the head injury criteria (HIC) limit values of 1,000 for the HIC1000 zone and 1,700 for the HIC1700 zone, especially in the points near to the borders between the two types of zones.

4. Child headform – Specific test procedure
 - 4.1. Tests shall be made to the front structure within the boundaries as defined in paragraph 2.16. of this Regulation. For tests on the rear area of the bonnet top, the headform impactor shall not contact the windscreen or A-pillar before impacting the bonnet top.
 - 4.2. A minimum of nine tests shall be carried out with the child headform impactor, three tests each to the middle and the outer thirds of the child/small adult bonnet top test areas, at positions judged to be the most likely to cause injury.

Tests shall be to different types of structure, where these vary throughout the area to be assessed and at positions judged to be the most likely to cause injury.
 - 4.3. The selected measuring points for the child/small adult headform impactor shall be a minimum of 165 mm apart and within the child headform test area as defined in paragraph 2.16. of this Regulation.

These minimum distances are to be set with a flexible tape held tautly along the outer surface of the vehicle.
 - 4.4. No measuring point shall be located so that the impactor will impact the test area with a glancing blow resulting in a more severe second impact outside the test area.
 - 4.5. For the child headform testing, a longitudinal and transversal impact tolerance of ± 10 mm shall apply. This tolerance is measured along the surface of the bonnet. The test laboratory may verify at a sufficient number of measuring points that this condition can be met and the tests are thus being conducted with the necessary accuracy.
 - 4.6. The headform velocity at the time of impact shall be $9.7 \text{ m/s} \pm 0.2 \text{ m/s}$.
 - 4.7. The direction of impact shall be in the longitudinal vertical plane of the vehicle to be tested at an angle of $50^\circ \pm 2^\circ$ to the horizontal. The direction of impact of tests to the front structure shall be downward and rearward.
5. Adult headform specific test procedure
 - 5.1. Tests shall be made to the front structure within the boundaries as defined in paragraph 2.1. of this Regulation. For tests at the rear of the bonnet top, the headform impactor shall not contact the windscreen or A-pillar before impacting the bonnet top.
 - 5.2. A minimum of nine tests shall be carried out with the adult headform impactor, three tests each to the middle and the outer thirds of the adult bonnet top test areas, at positions judged to be the most likely to cause injury.

Tests shall be to different types of structure, where these vary throughout the area to be assessed and at positions judged to be the most likely to cause injury.
 - 5.3. The selected measuring points on the bonnet for the adult headform impactor shall be a minimum of 165 mm apart and within the adult headform test area as defined in paragraph 2.1. of this Regulation.

These minimum distances are to be set with a flexible tape held tautly along the outer surface of the vehicle.

- 5.4. No measuring point shall be located so that the impactor will impact the test area with a glancing blow resulting in a more severe second impact outside the test area.
- 5.5. For the adult headform testing, a longitudinal and transversal impact tolerance of ± 10 mm shall apply. This tolerance is measured along the surface of the bonnet. The test laboratory may verify at a sufficient number of measuring points that this condition can be met and the tests are thus being conducted with the necessary accuracy.
- 5.6. The headform velocity at the time of impact shall be $9.7 \text{ m/s} \pm 0.2 \text{ m/s}$.
- 5.7. The direction of impact shall be in the longitudinal vertical plane of the vehicle to be tested at an angle of $65^\circ \pm 2^\circ$ to the horizontal. The direction of impact of tests to the front structure shall be downward and rearward.

Annex 6

Certification of the impactor

1. Flexible lower legform impactor certification
 - 1.1. The impactor shall be certified using two certification tests as follows: First, the certification shall be conducted according to the inverse certification (IC) test procedure prescribed in paragraph 1.4. of this annex before starting a vehicle test series. Second, after a maximum of 10 vehicle tests, certification should be conducted according to the pendulum certification (PC) test procedure prescribed in paragraph 1.3. of this annex. Ongoing certification testing then shall constitute the sequence IC – PC – PC – IC – PC – PC – etc. with a maximum of 10 tests between each certification.

In addition, the impactor shall be certified according to the procedures prescribed in paragraph 1.2. below at least once a year.
 - 1.2. Static certification tests
 - 1.2.1. The femur and the tibia of the flexible lower legform impactor shall meet the requirements specified in paragraph 1.2.2. of this annex when tested according to paragraph 1.2.4. of this annex. The knee joint of the lower legform impactor shall meet the requirements specified in paragraph 1.2.3. of this annex when tested according to paragraph 1.2.5 of this annex. The stabilized temperature of the impactor during the certification tests shall be $20\text{ °C} \pm 2\text{ °C}$.

The CAC response values, as defined in ISO 6487:2002, shall be 30 mm for the knee ligament elongations and 4 kN for the applied external load. For these tests, low-pass filtering at an appropriate frequency is permitted to remove higher frequency noise without significantly affecting the measurement of the response of the impactor.
 - 1.2.2. When the femur and the tibia of the impactor are loaded in bending in accordance with paragraph 1.2.4. below, the applied moment and the generated deflection at the centre of the femur and the tibia (M_c and D_c) shall be within the corridors shown in Figure 1.
 - 1.2.3. When the knee joint of the impactor is loaded in bending in accordance with paragraph 1.2.5. of this annex, the MCL, ACL, and PCL elongations and applied bending moment or the force at the centre of the knee joint (M_c or F_c) shall be within the corridors shown in Figure 2.
 - 1.2.4. The edges of the femur and tibia, not bending parts, shall be mounted to the support rig firmly as shown in Figure 3 and Figure 4. The Y-axis of the impactor shall be parallel to the loading axis within $180^\circ \pm 2^\circ$ tolerance. To obtain repeatable loading, low friction Polytetrafluoroethylene (PTFE) plastic pads are used under each support (see Figure 3 and Figure 4).

The centre of the loading force shall be applied at the centre of the femur and the tibia within ± 2 mm tolerance along the Z-axis. The force shall be increased so as to maintain a deflection rate between 10 and 100 mm/minute until the bending moment at the centre part (M_c) of the femur or tibia reaches 380 Nm.
 - 1.2.5. The ends of the knee joint shall be mounted to the support rig firmly as shown in Figure 5. The Y-axis of the impactor shall be parallel to the loading axis

within $\pm 2^\circ$ tolerance. To obtain repeatable loading, low friction Polytetrafluoroethylene (PTFE) plastic pads are used under each support (see Figure 5). To avoid impactor damage, a neoprene sheet shall be set underneath the loading ram and the impactor face of the knee joint which is described in the Figure 3 of Annex 4 shall be removed. The neoprene sheet used in this test shall have compression characteristics as shown in Figure 2 (b) of Annex 5.

The centre of the loading force shall be applied at the knee joint center within ± 2 mm tolerance along the Z-axis (see Figure 5 below). The external load shall be increased so as to maintain a deflection rate between 10 and 100 mm/minute until the bending moment at the centre part of the knee joint (M_c) reaches 400 Nm.

1.3. Dynamic certification tests (pendulum test)

1.3.1. Certification

1.3.1.1. The test facility used for the certification test shall have a stabilized temperature of $20\text{ }^\circ\text{C} \pm 2\text{ }^\circ\text{C}$ during the test.

1.3.1.2. The temperature of the certification area shall be measured at the time of certification and recorded in a certification report.

1.3.2. Requirements

1.3.2.1. When the flexible lower legform impactor is used for a test according to paragraph 1.3.3. below, the absolute value of the maximum bending moment of the tibia at:

- (a) Tibia-1 shall be $235\text{ Nm} \leq 272\text{ Nm}$;
- (b) Tibia-2 shall be $187\text{ Nm} \leq 219\text{ Nm}$;
- (c) Tibia-3 shall be $139\text{ Nm} \leq 166\text{ Nm}$;
- (d) Tibia-4 shall be $90\text{ Nm} \leq 111\text{ Nm}$.

The absolute value of the maximum elongation of:

- (a) MCL shall be $20.5 \leq 24.0\text{ mm}$;
- (b) ACL shall be $8.0\text{ mm} \leq 10.5\text{ mm}$;
- (c) PCL shall be $3.5\text{ mm} \leq 5.0\text{ mm}$.

For all these values for the maximum bending moment and the maximum elongation, the readings used shall be from the initial impact timing to 200 ms after the impact timing.

1.3.2.2. The instrumentation response value CFC, as defined in ISO 6487:2002, shall be 180 for all transducers. The CAC response values, as defined in ISO 6487:2002, shall be 30 mm for the knee ligament elongations and 400 Nm for the tibia bending moments.

- 1.3.3. Test procedure
- 1.3.3.1. The flexible lower legform impactor, including the flesh and skin, shall be suspended from the dynamic certification test rig $15^\circ \pm 1^\circ$ upward from the horizontal as shown in Figure 6 below. The impactor shall be released from the suspended position and fall freely against the pin joint of the test rig as shown in Figure 6.
- 1.3.3.2. The knee joint centre of the impactor shall be $30 \text{ mm} \pm 1 \text{ mm}$ below the bottom line of the stopper bar, and the tibia impact face without the flesh and skin shall be located $13 \text{ mm} \pm 2 \text{ mm}$ from the front upper edge of the stopper bar when the impactor is hanging freely as shown in Figure 6 below.
- 1.4. Dynamic certification tests (inverse test)
- 1.4.1. Certification
- 1.4.1.1. The test facility used for the certification test shall have a stabilized temperature of $20 \text{ }^\circ\text{C} \pm 2 \text{ }^\circ\text{C}$ during the test.
- 1.4.1.2. The temperature of the certification area shall be measured at the time of certification and recorded in a certification report.
- 1.4.2. Requirements
- 1.4.2.1. When the flexible lower legform impactor is used for the test according to paragraph 1.4.3. of this annex, the absolute value of the maximum bending moment of the tibia:
- (a) Tibia-1 shall be $230 \text{ Nm} \leq 272 \text{ Nm}$;
 - (b) Tibia-2 shall be $210 \text{ Nm} \leq 252 \text{ Nm}$;
 - (c) Tibia-3 shall be $166 \text{ Nm} \leq 192 \text{ Nm}$;
 - (d) Tibia-4 shall be $93 \text{ Nm} \leq 108 \text{ Nm}$.
- The absolute value of the maximum elongation of:
- (a) MCL shall be $17.0 \leq 21.0 \text{ mm}$;
 - (b) ACL shall be $8.0 \text{ mm} \leq 10.0 \text{ mm}$;
 - (c) PCL shall be $4.0 \text{ mm} \leq 6.0 \text{ mm}$.
- For all these values for the maximum bending moment and the maximum elongation, the readings used shall be from the initial impact timing to 50 ms after the impact timing.
- 1.4.2.2. The instrumentation response value CFC, as defined in ISO 6487:2002, shall be 180 for all transducers. The CAC response values, as defined in ISO 6487:2002, shall be 30 mm for the knee ligament elongations and 400 Nm for the tibia bending moments.
- 1.4.3. Test procedure
- 1.4.3.1. The assembled flexible lower legform impactor (with the flesh and skin) shall be hung vertically and freely suspended from a test rig as shown in Figure 7 below. It is then impacted by the upper edge of a linearly guided aluminium honeycomb impactor, covered by a thin paper cloth with a maximum thickness of 1 mm, at an impact speed of $11.1 \text{ m/s} \pm 0.2 \text{ m/s}$. The legform shall achieve a free flight condition within 10 ms after the time of first contact of the honeycomb impactor.

- 1.4.3.2. The honeycomb of 5052 alloy, which is attached in front of the moving ram, shall be 200 mm \pm 5 mm wide, 160 mm \pm 5 mm high and 60 mm \pm 2 mm deep and shall have a crush strength of 75 pound per square inch (psi) \pm 10 per cent. The honeycomb should have cell sizes of either 3/16 inch or ¼ inch and a density of 2.0 pound per cubic foot (pcf) for the 3/16 inch cell size or a density of 2.3 pcf for the ¼ inch cell size.
- 1.4.3.3. The upper edge of the honeycomb face shall be in line with the rigid plate of the linearly guided impactor. At the time of first contact, the upper edge of the honeycomb shall be in line with the knee joint centre line within a vertical tolerance of \pm 2 mm.
- The honeycomb shall not be deformed before the impact test.
- 1.4.3.4. At the time of the first contact, the flexible lower legform impactor pitch angle (rotation around the Y-axis) and therefore the pitch angle of the velocity vector of the honeycomb impactor shall be within a tolerance of \pm 2° in relation to the lateral vertical plane. The flexible lower legform impactor roll angle (rotation around the X-axis) and therefore the roll angle of the honeycomb impactor shall be within a tolerance of \pm 2° in relation to the longitudinal vertical plane. The flexible lower legform impactor yaw angle (rotation around the Z-axis) and therefore the yaw angle of the velocity vector of the honeycomb impactor shall be within a tolerance of \pm 2°.
2. Upper legform impactor certification
- 2.1. The certified impactor may be used for a maximum of 20 impacts before re-certification (this limit does not apply to propulsion or guidance components). The impactor shall also be re-certified if more than one year has elapsed since the previous certification or if any impactor transducer output, in any impact, has exceeded the specified CAC.
- 2.2. Certification
- 2.2.1. The foam flesh for the test impactor shall be stored for a period of at least four hours in a controlled storage area with a stabilized humidity of 35 \pm 10 per cent and a stabilized temperature of 20 °C \pm 2 °C prior to impactor removal for certification. The test impactor itself shall have a temperature of 20 °C \pm 2 °C at the time of impact. The temperature tolerances for the test impactor shall apply at a relative humidity of 40 \pm 30 per cent after a soak period of at least four hours prior to their application in a test.
- 2.2.2. The test facility used for the certification test shall have a stabilized humidity of 40 \pm 30 per cent and a stabilized temperature of 20 °C \pm 4 °C during certification.
- 2.2.3. Each certification shall be completed within two hours of when the impactor to be calibrated is removed from the controlled storage area.
- 2.2.4. The relative humidity and temperature of the certification area shall be measured at the time of certification, and recorded in the certification report.
- 2.3. Requirements
- 2.3.1. When the impactor is propelled into a stationary cylindrical pendulum the peak force measured in each load transducer shall be not less than 1.20 kN and not more than 1.55 kN and the difference between the peak forces measured in the top and bottom load transducers shall not be more than 0.10 kN. Also, the peak

bending moment measured by the strain gauges shall not be less than 190 Nm and not more than 250 Nm on the centre position and not less than 160 Nm and not more than 220 Nm for the outer positions. The difference between the upper and lower peak bending moments shall not be more than 20 Nm.

For all these values, the readings used shall be from the initial impact with the pendulum and not from the arresting phase. Any system used to arrest the impactor or pendulum shall be so arranged that the arresting phase does not overlap in time with the initial impact. The arresting system shall not cause the transducer outputs to exceed the specified CAC.

- 2.3.2. The instrumentation response value CFC, as defined in ISO 6487:2002, shall be 180 for all transducers. The CAC response values, as defined in ISO 6487:2002, shall be 10 kN for the force transducers and 1,000 Nm for the bending moment measurements.
- 2.4. Test procedure
- 2.4.1. The impactor shall be mounted to the propulsion and guidance system, by a torque limiting joint. The torque limiting joint shall be set so that the longitudinal axis of the front member is perpendicular to the axis of the guidance system, with a tolerance of $\pm 2^\circ$, with the joint friction torque set to $675 \text{ Nm} \pm 25 \text{ Nm}$. The guidance system shall be fitted with low friction guides that allow the impactor to move only in the specified direction of impact, when in contact with the pendulum.
- 2.4.2. The impactor mass shall be adjusted to give a mass of $12 \text{ kg} \pm 0.1 \text{ kg}$, this mass includes those propulsion and guidance components which are effectively part of the impactor during impact.
- 2.4.3. The centre of gravity of those parts of the impactor which are effectively forward of the torque limiting joint, including the extra masses fitted, shall lie on the longitudinal centreline of the impactor, with a tolerance of $\pm 10 \text{ mm}$.
- 2.4.4. The impactor shall be certified with previously unused foam.
- 2.4.5. The impactor foam shall not be excessively handled or deformed before, during or after fitting.
- 2.4.6. The impactor with the front member vertical shall be propelled horizontally at a velocity of $7.1 \text{ m/s} \pm 0.1 \text{ m/s}$ into the stationary pendulum as shown in Figure 8.
- 2.4.7. The pendulum tube shall have a mass of $3 \text{ kg} \pm 0.03 \text{ kg}$, a wall thickness of $3 \text{ mm} \pm 0.15 \text{ mm}$ and an outside diameter of $150 \text{ mm} +1 \text{ mm}/-4 \text{ mm}$. Total pendulum tube length shall be $275 \text{ mm} \pm 25 \text{ mm}$. The pendulum tube shall be made from cold finished seamless steel (metal surface plating is permissible for protection from corrosion), with an outer surface finish of better than 2.0 micrometer. It shall be suspended on two wire ropes of $1.5 \text{ mm} \pm 0.2 \text{ mm}$ diameter and of 2.0 m minimum length. The surface of the pendulum shall be clean and dry. The pendulum tube shall be positioned so that the longitudinal axis of the cylinder is perpendicular to the front member (i.e. level), with a tolerance of $\pm 2^\circ$, and to the direction of impactor motion, with a tolerance of $\pm 2^\circ$, and with the centre of the pendulum tube aligned with the centre of the impactor front member, with tolerances of $\pm 5 \text{ mm}$ laterally and $\pm 5 \text{ mm}$ vertically.

3. Child and adult headform
 - 3.1. The certified impactors may be used for a maximum of 20 impacts before re-certification. The impactors shall be re-certified if more than one year has elapsed since the previous certification or if the transducer output, in any impact, has exceeded the specified CAC.
 - 3.2. Drop test
 - 3.2.1. When the headform impactors are dropped from a height of 376 mm \pm 1 mm in accordance with paragraph 3.3. below, the peak resultant acceleration measured by one triaxial (or three uniaxial) accelerometer (accelerometers) in the headform impactor shall be:
 - (a) For the child headform impactor not less than 245 g and not more than 300 g;
 - (b) For the adult headform impactor not less than 225 g and not more than 275 g.The acceleration time curve shall be uni-modal.
 - 3.2.2. The instrumentation response values CFC and CAC for each accelerometer shall be 1,000 Hz and 500 g respectively as defined in ISO 6487:2002.
 - 3.2.3. The headform impactors shall have a temperature of 20 °C \pm 2 °C at the time of impact. The temperature tolerances shall apply at a relative humidity of 40 \pm 30 per cent after a soak period of at least four hours prior to their application in a test.
 - 3.3. Test procedure
 - 3.3.1. The headform impactor shall be suspended from a drop rig as shown in Figure 9.
 - 3.3.2. The headform impactor shall be dropped from the specified height by means that ensure instant release onto a rigidly supported flat horizontal steel plate, over 50 mm thick and over 300 mm x 300 mm square which has a clean dry surface and a surface finish of between 0.2 and 2.0 micrometer.
 - 3.3.3. The headform impactor shall be dropped with the rear face of the impactor at the test angle specified in Annex 5, paragraph 4.7. for the child headform impactor and in Annex 5, paragraph 5.7. for the adult headform impactor with respect to the vertical as shown in Figure 9 below. The suspension of the headform impactor shall be such that it does not rotate during the fall.
 - 3.3.4. The drop test shall be performed three times, with the headform impactor rotated 120° around its symmetrical axis after each test.

Figure 1
Flexible lower legform impactor: Requirement corridors of the femur and the tibia in the static certification test (see paragraph 1.2.2. of this annex)

(a) Femur bending corridor

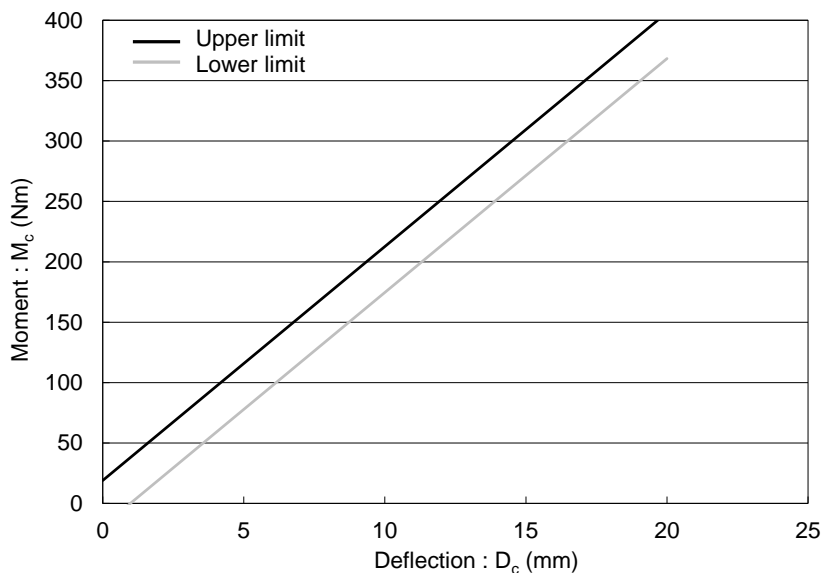

(b) Tibia bending corridor

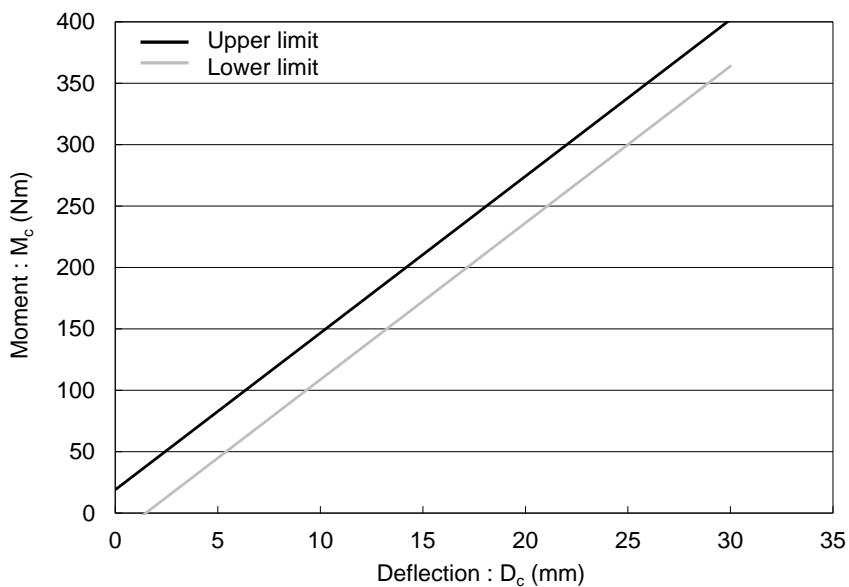
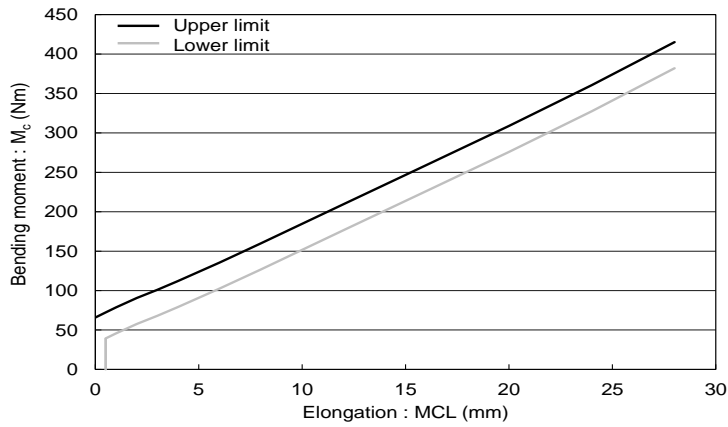
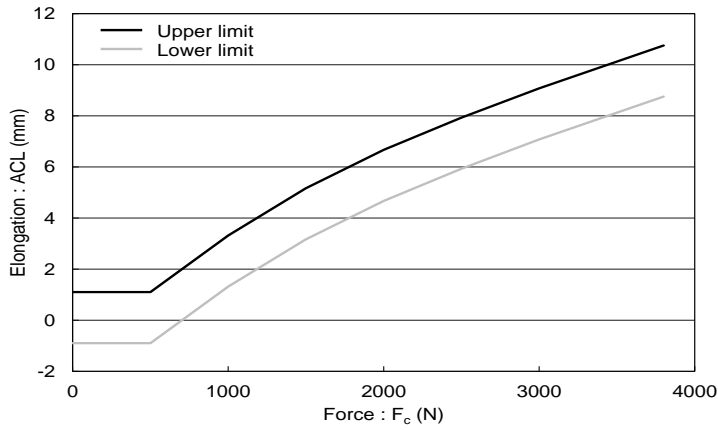

Figure 2
Flexible lower legform impactor: Requirement corridors for the knee joint in the static certification test (see paragraph 1.2.3. of this annex)



(a) for MCL



(b) for ACL

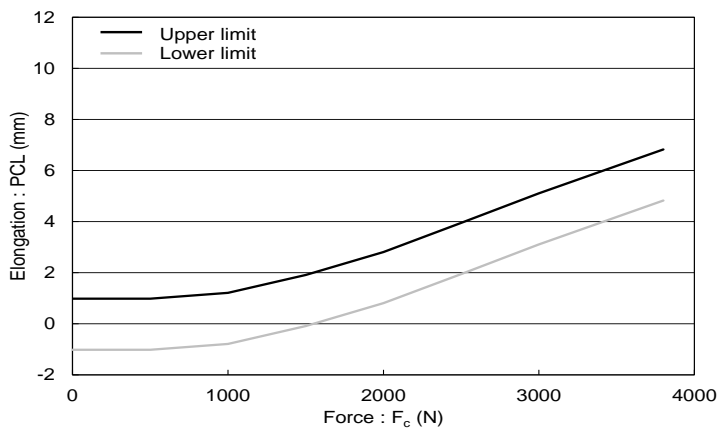

(c) for PCL

Figure 3
Flexible lower legform: Impactor test set-up for the femur in the static certification test
 (see paragraph 1.2.4. of this annex)

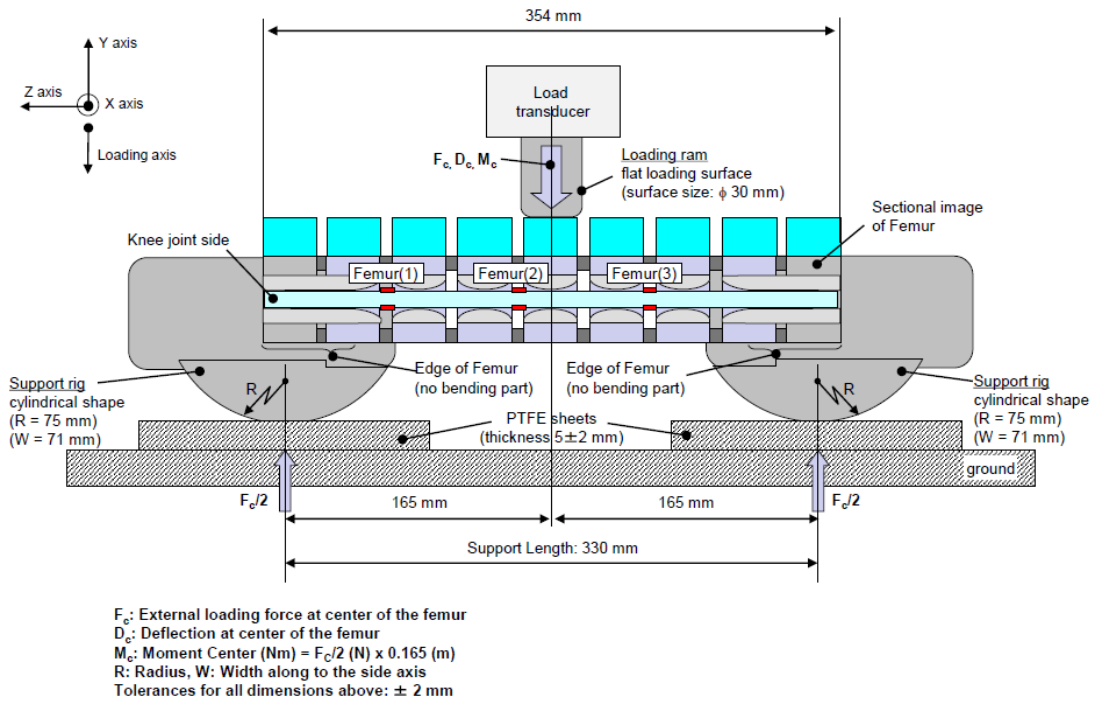

Figure 4
Flexible lower legform impactor: Test set-up for the tibia in the static certification test
 (see paragraph 1.2.4. of this annex)

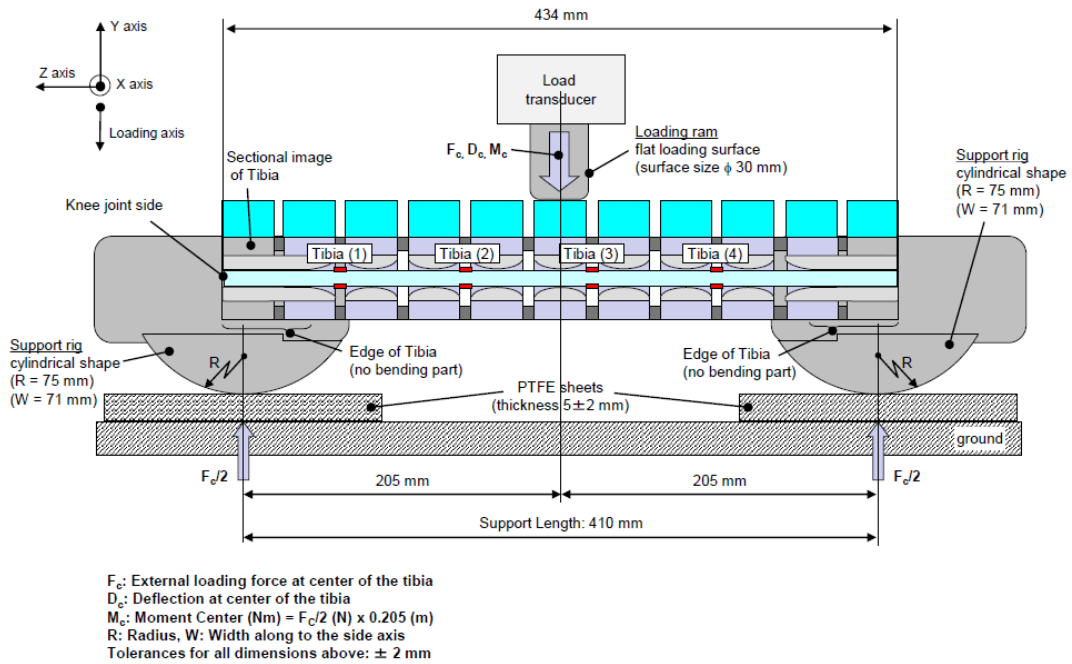
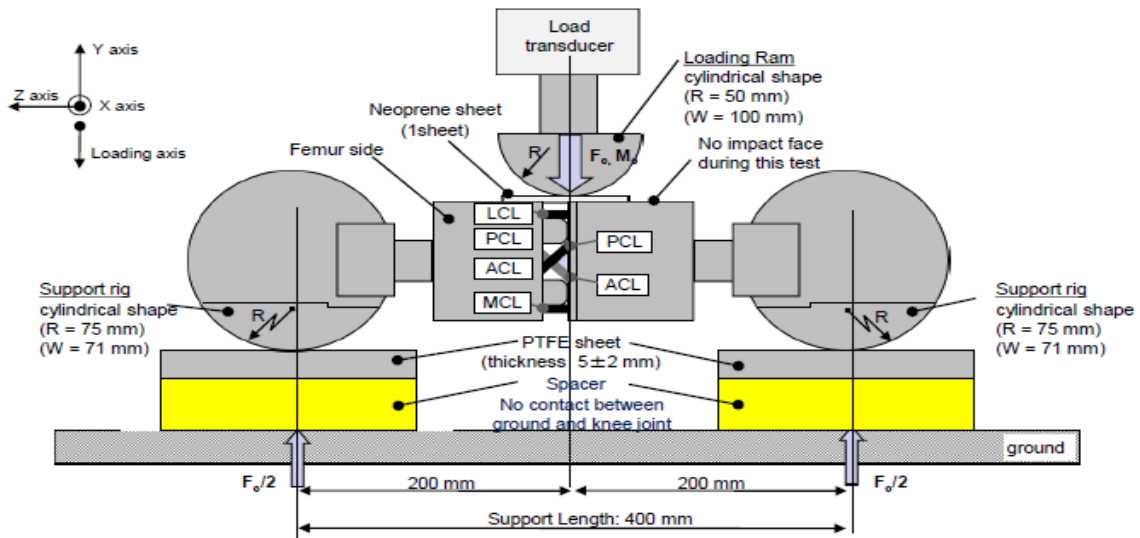

Figure 5
Flexible lower legform impactor: Test set-up for the knee joint in the static certification test (see paragraph 1.2.5. of this annex)



F_o : External loading force at center of knee joint
 M_o : Moment center (Nm) = $F_o/2$ (N) x 0.2 (m)
 R: Radius, W: Width along to the side axis
 Tolerances for all dimensions above: ± 2 mm

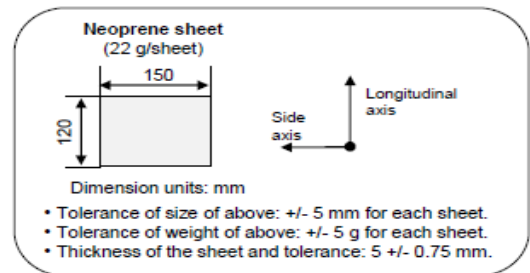

Figure 6
Flexible lower legform impactor: Test set-up for the dynamic lower legform impactor certification test (pendulum test, see paragraph 1.3.3.1. of this annex)

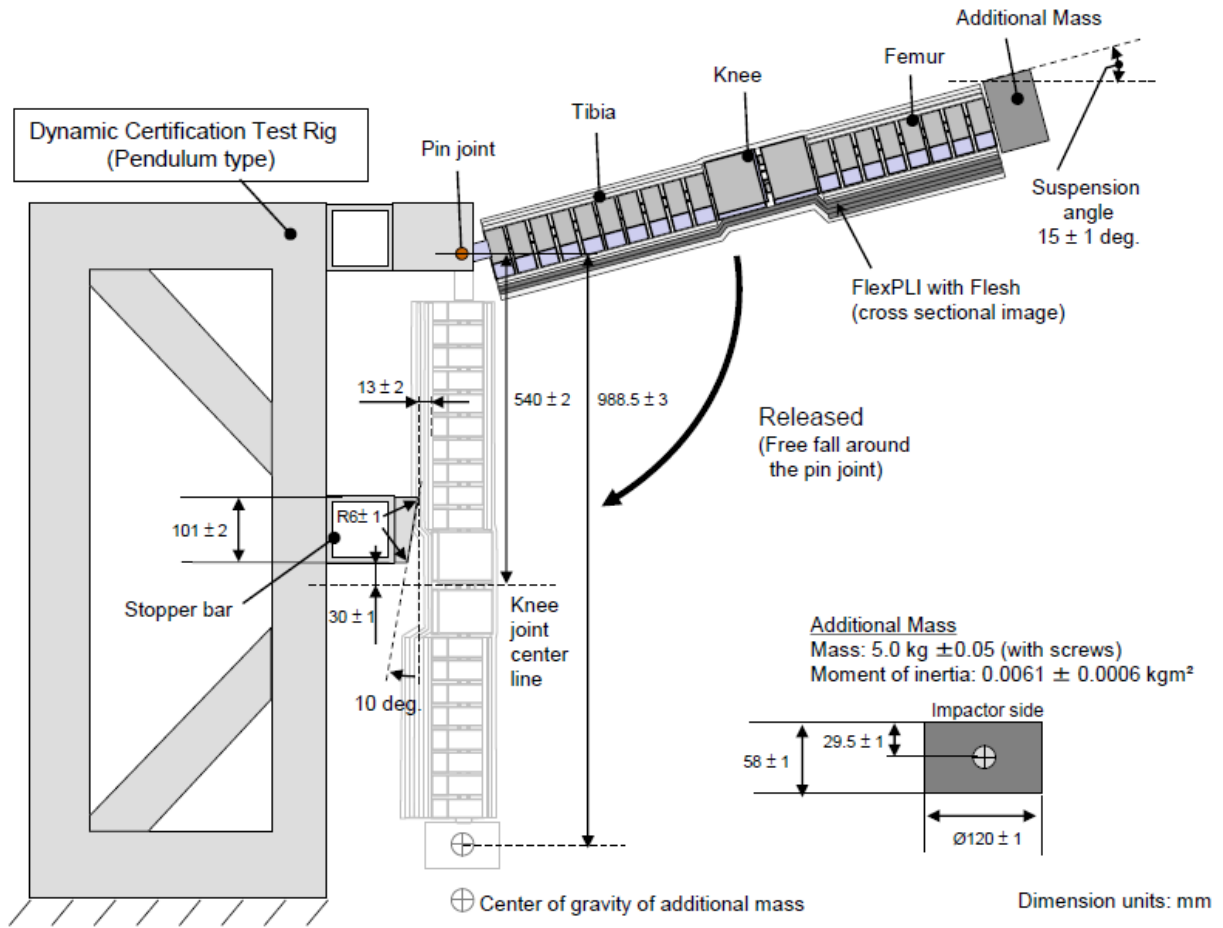

Figure 7
Flexible lower legform impactor: Test set-up for the dynamic lower legform impactor certification test (inverse test, see paragraph 1.4.3.1. of this annex)

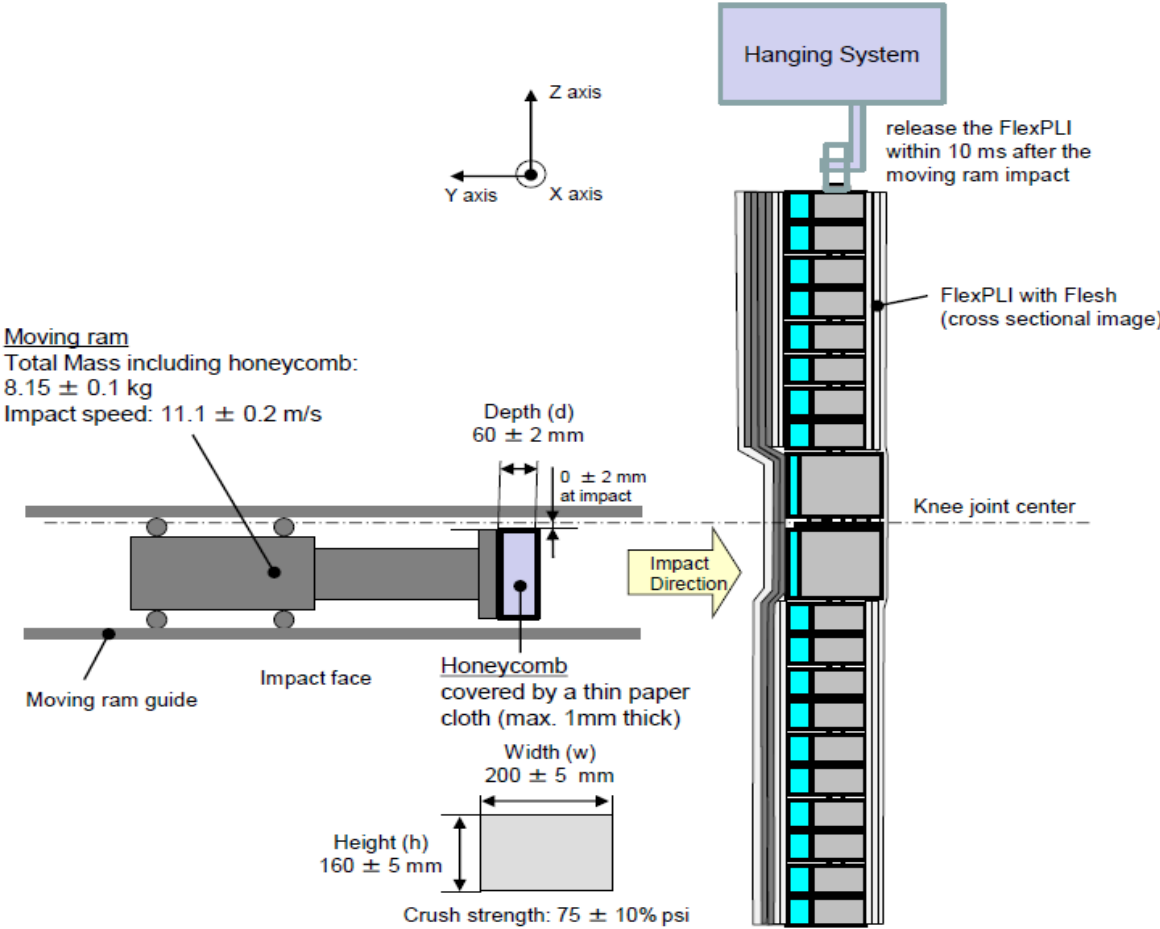

Figure 8
Test set-up for dynamic upper legform impactor certification test

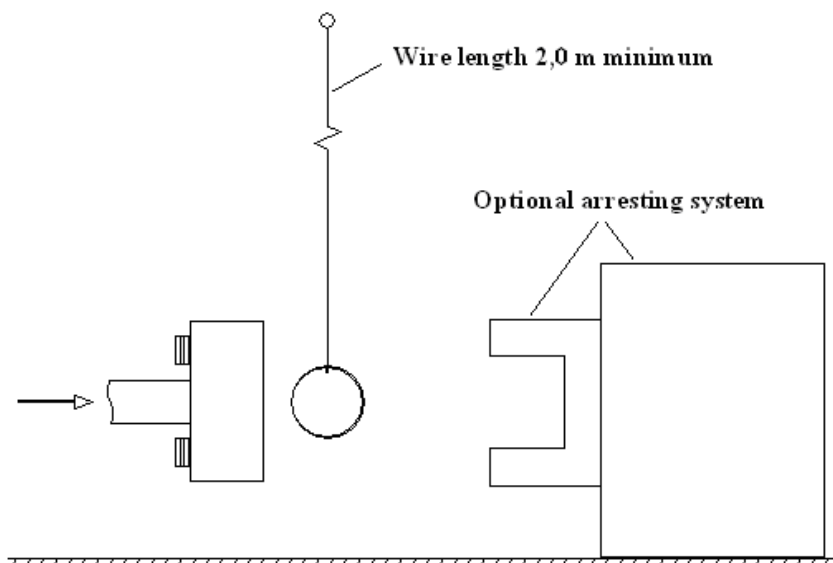

Figure 9
Test set-up for dynamic headform impactor biofidelity test

