



595 SERIES COMPACT COMBINATION LAMP

With Dynamic Indicator and Diffused Tail Light

- 12/24V multivolt
- Progressive indicator sequence
- Diffused tail light
- Black-chrome housing

- Fully ECE approved
- IP67 - fully waterproof
- 5 year warranty
- Highly efficient LED technology

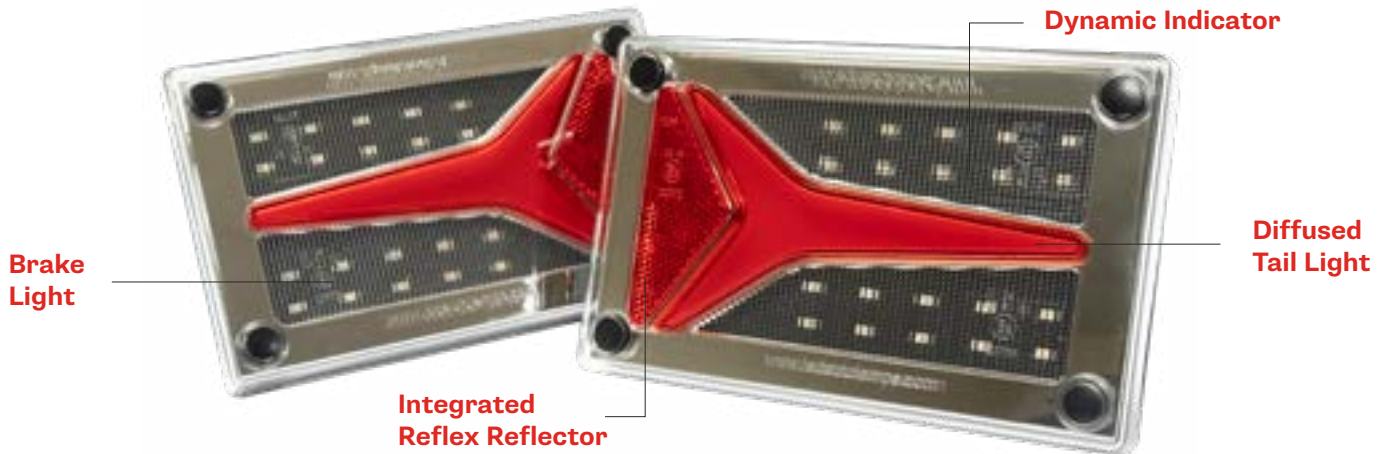

12/24V
DUAL
VOLTAGE

IP67
100%
WATERPROOF

5
FIVE YEAR
WARRANTY

R3
ECE
APPROVED

R6
ECE
APPROVED

R7
ECE
APPROVED

R10
ECE
APPROVED



PROGRESSIVE INDICATOR SEQUENCE

DIFFUSED TAIL

Compact Combination Lamp STOP / TAIL / INDICATOR / REFLECTOR



595STIML Left

595STIMR Right

595STIMLR2 Twin Pack

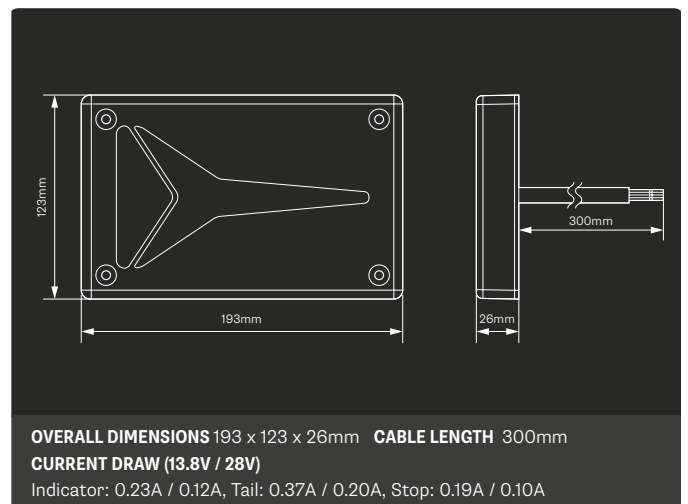

OVERALL DIMENSIONS 193 x 123 x 26mm **CABLE LENGTH** 300mm

CURRENT DRAW (13.8V / 28V)

Indicator: 0.23A / 0.12A, Tail: 0.37A / 0.20A, Stop: 0.19A / 0.10A

- Exclusive LED Autolamps design
- Shock and vibration tested