

2 January 2012

Agreement

Concerning the adoption of uniform technical prescriptions for wheeled vehicles, equipment and parts which can be fitted and/or be used on wheeled vehicles and the conditions for reciprocal recognition of approvals granted on the basis of these prescriptions*

(Revision 2, including the amendments which entered into force on 16 October 1995)

Addendum 28: Regulation No. 29

Revision 2

Incorporating all valid text up to:

02 series of amendments - Date of entry into force: 27 February 1999

Supplement 1 to the series 02 of amendments - Date of entry into force: 11 June 2007

03 series of amendments - Date of entry into force: 30 January 2011

Uniform provisions concerning the approval of vehicles with regard to the protection of the occupants of the cab of a commercial vehicle



UNITED NATIONS

* Former title of the Agreement: Agreement Concerning the Adoption of Uniform Conditions of Approval and Reciprocal Recognition of Approval for Motor Vehicle Equipment and Parts, done at Geneva on 20 March 1958.

Regulation No. 29

Uniform provisions concerning the approval of vehicles with regard to the protection of the occupants of the cab of a commercial vehicle

Contents

	<i>Page</i>
1. Scope	4
2. Definitions.....	4
3. Application for approval	5
4. Approval	5
5. Requirements.....	6
6. Modifications and extension of the approval of the vehicle type.....	7
7. Conformity of production.....	7
8. Penalties for non-conformity of production	7
9. Production definitely discontinued.....	8
10. Transitional provisions.....	8
11. Names and addresses of Technical Services responsible for conducting approval tests and of Type Approval Authorities	9
Annexes	
1 ECE Type-approval documentation	10
Part 1 – Model information document.....	10
Part 2 – Communication.....	12
2 Arrangements of approval marks	13
3 Test procedure.....	14
Appendix 1: Instructions for securing vehicles to the test bed.....	18
Appendix 2: Manikin to be used to verify the survival space	21
4 Procedure for determining the "H" point and the actual torso angle for seating positions in motor vehicles	23
Appendix 1: Description of the three-dimensional H point machine (3-D H machine).....	24
Appendix 2: Three dimensional reference system	25
5 Reference data concerning seating positions.....	26

1. Scope

This Regulation applies to vehicles with separate driver's cab of category N¹ with regard to the protection of the occupants of the cab.

2. Definitions

For the purposes of this Regulation:

- 2.1. "*Approval of a vehicle*" means the approval of a vehicle type pursuant to the requirements of this Regulation, with regard to the protection of the occupants of the cab of a vehicle in the event of head-on impact or of overturning.
- 2.2. "*Vehicle type*" means a category of motor vehicle which does not differ in such essential respects as:
 - 2.2.1. The dimensions, shapes and materials of the components of the vehicle cab; or
 - 2.2.2. The manner of attachment of the cab to the chassis frame;
- 2.3. "*Transverse plane*" means a vertical plane perpendicular to the longitudinal plane of the vehicle;
- 2.4. "*Longitudinal plane*" means a plane parallel to the median longitudinal plane of the vehicle;
- 2.5. "*Cab-over engine vehicle*" means a vehicle where more than half of the engine length is rearward of the foremost point of the windshield base and the steering wheel hub is in the forward quarter of the vehicle length.
- 2.6. "*R point*" means the seating reference point as defined in Annex 4, paragraph 2.4.
- 2.7. "*H-point*" means the point defined in Annex 4, paragraph 2.3.
- 2.8. "*Test A*" means a frontal impact test intended to evaluate the resistance of a cab in frontal impact accident.
- 2.9. "*Test B*" means an impact test to the A-pillars of the cab intended to evaluate the resistance of a cab in a 90° rollover accident with subsequent impact.
- 2.10. "*Test C*" means a cab roof strength test intended to evaluate the resistance of a cab in a 180° rollover accident.
- 2.11. "*A-pillar*" means the foremost and outermost roof support.
- 2.12. "*Windscreen*" means the frontal glazing of the vehicle situated between the A-pillars.

¹ As defined in the Consolidated Resolution on the Construction of Vehicles (R.E.3.), document ECE/TRANS/WP.29/78/Rev.2, para. 2

3. Application for approval

- 3.1. The application for approval of a vehicle type with regard to the protection of the occupants of the cab of a vehicle shall be submitted by the vehicle manufacturer or by his duly accredited representative.
- 3.2. It shall be accompanied by drawings of the vehicle, showing the position of the cab on the vehicle and the manner of its attachment, and by sufficiently detailed drawings relating to the structure of the cab, all the said drawings being submitted in triplicate. A model for the information document relating to the construction features is given in Annex 1, Part 1.

4. Approval

- 4.1. If the vehicle type submitted for approval pursuant to this Regulation meets the requirements of paragraph 5 hereof, approval of that vehicle type shall be granted.
- 4.2. An approval number shall be assigned to each type approved. Its first two digits (at present 03 corresponding to the 03 series of amendments) shall indicate the series of amendments incorporating the most recent major technical amendments made to the Regulation at the time of issue of the approval. The same Contracting Party may not assign the same number to another vehicle type within the meaning of paragraph 2.2 above.
- 4.3. Notice of approval or of extension or of refusal or of withdrawal of approval or production definitely discontinued of a vehicle type pursuant to this Regulation shall be communicated by the Parties to the Agreement which apply this Regulation by means of a form conforming to the model in annex 1 to this Regulation.
- 4.4. There shall be affixed, conspicuously and in a readily accessible place specified on the approval form, to every vehicle conforming to a vehicle type approved under this Regulation, an international approval mark consisting of:
 - 4.4.1. A circle surrounding the letter "E" followed by the distinguishing number of the country which has granted the approval² and
 - 4.4.2. the number of this Regulation, followed by the letter "R", a dash and the approval number, to the right of the circle prescribed in paragraph 4.4.1.;
- 4.5. If the vehicle conforms to a vehicle type approved, under one or more other Regulations annexed to the Agreement, in the country which has granted approval under this Regulation, the symbol prescribed in paragraph 4.4.1. need not be repeated; in such a case the additional numbers and symbols of all the Regulations under which approval has been granted in the country which has granted approval under this Regulation shall be placed in vertical columns to the right of the symbol prescribed in paragraph 4.4.1.
- 4.6. The approval mark shall be clearly legible and be indelible.
- 4.7. The approval mark shall be placed close to or on the vehicle data plate.

² The distinguish numbers of the Contracting Parties to the 1958 Agreement are reproduced in Annex 3 to Consolidated Resolution on the Construction of Vehicles (R.E.3), document ECE/TRANS/WP.29/78/Rev.2.

- 4.8. Annex 2 to this Regulation gives examples of arrangements of approval marks.

5. Requirements

5.1. General requirements

- 5.1.1. The cab of the vehicle shall be so designed and so attached to the vehicle as to eliminate to the greatest possible extent the risk of injury to the occupants in the event of an accident.

- 5.1.2. Vehicles of categories N_1 and vehicles of categories N_2 with a gross vehicle mass not exceeding 7.5 t shall be subjected to the tests A and C, as described in Annex 3, paragraphs 5. and 7..

However a vehicle type which has been approved according to Regulation No. 33 or to Regulation No. 94 may be considered to have satisfied the requirements on frontal impact (test A).

- 5.1.3. Vehicles of categories N_3 and vehicles of categories N_2 with a gross vehicle mass exceeding 7.5 t shall be subjected to the tests A, B, and C, as described in Annex 3, paragraphs 5., 6. and 7..

- 5.1.4. Test A (frontal impact) shall only be conducted on Cab-over-Engine vehicles.

- 5.1.5. One, two or three cabs, at the manufacturer's choice, may be used for the purpose of demonstrating compliance with paragraphs 5.1.2. or 5.1.3. above. However both phases in test C, if applicable, shall be conducted on the same cab.

- 5.1.6. None of the tests A, B, C, need be carried out if the manufacturer can show by computer simulation or calculations of the strength of the component parts of the cab or by other means to the satisfaction of the Technical Service that the cab will not undergo deformation dangerous to the occupants (penetration into the survival space) if subjected to the conditions of the tests.

5.2. Survival space required after the test or tests

- 5.2.1. After undergoing each of the tests referred to in paragraphs 5.1.2. or 5.1.3., the cab of the vehicle shall exhibit a survival space allowing accommodation of the manikin defined in Annex 3, Appendix 2, on the seat, when the latter is in its median position, without contact between the test manikin and non-resilient parts with a Shore-Hardness of 50 or more. No account shall be taken of non-resilient parts which can be moved away without any tools from the test manikin by using a force of less than 100 N. To facilitate installation, the manikin may be inserted in dismantled form and assembled in the cab. For this purpose, the seat shall be adjusted to its most rearward position and the manikin completely assembled and so placed that its H point coincides with the R point. The seat shall then be moved forward to its median position for the assessment of the survival space. As an alternative to the test manikin defined in Annex 3, Appendix 2, a fiftieth percentile Hybrid II or III male dummy, with or without measuring instrumentation, the description of which is given in Regulation No. 94, may be used.

- 5.2.2. The space so defined shall be verified for every seat provided by the manufacturer.

- 5.3. Other conditions
- 5.3.1. During the tests the components by which the cab is secured to the chassis frame may be distorted or broken, provided that the cab remains attached to the chassis frame.
- 5.3.2. None of the doors shall open during the tests, but the doors shall not be required to open after testing.

6. Modification and extension of approval of the vehicle type

- 6.1. Every modification of the vehicle type shall be notified to the Type Approval Authority which approved the vehicle type. The department may then either:
 - 6.1.1. Consider that the modifications made are unlikely to have an appreciable adverse effect, and that in any case the vehicle still complies with the requirements;
 - 6.1.2. Or require a further test report from the Technical Service responsible for conducting the tests.
- 6.2. Confirmation or refusal of approval, specifying the alterations, shall be communicated by the procedure specified in paragraph 4.3. above to the Contracting Parties to the Agreement which apply this Regulation.
- 6.3. The competent authority issuing an extension of approval shall assign a series number for such an extension and inform thereof the other Parties to the 1958 Agreement applying this Regulation by means of a communication form conforming to the model in Annex 1 to this Regulation.

7. Conformity of production

The conformity of production procedures shall comply with those set out in the Agreement, Appendix 2 (E/ECE/324-E/ECE/TRANS/505/Rev.2), with the following requirements:

- 7.1. A vehicle approved pursuant to this Regulation shall be so manufactured as to conform to the type approved by meeting the requirements of paragraph 5. above.
- 7.2. The Competent Authority which has granted approval may at any time verify the conformity of control methods applicable to each production unit. The normal frequency of such inspections shall be once every two years.

8. Penalties for non-conformity of production

- 8.1. The approval granted in respect of a vehicle type, pursuant to this Regulation, may be withdrawn if the requirement laid down in paragraph 7.1. above is not complied with.
- 8.2. If a Party to the Agreement which applies this Regulation withdraws an approval it has previously granted, it shall forthwith so notify the other Contracting Parties applying this Regulation by means of a communication form conforming to the model in Annex 1 to this Regulation.

9. Production definitely discontinued

If the holder of the approval completely ceases to manufacture a type of vehicle approved in accordance with this Regulation, he shall so inform the authority which granted the approval. Upon receiving the relevant communication, that authority shall inform thereof the other Parties to the 1958 Agreement which apply this Regulation by means of a communication form conforming to the model in Annex 1 to this Regulation.

10. Transitional provisions

- 10.1. As from the official date of entry into force of the 02 series of amendments, no Contracting Party applying this Regulation shall refuse to grant ECE approval under this Regulation as amended by the 02 series of amendments.
- 10.2. As from 1 October 2002 Contracting Party applying this Regulation shall grant ECE approvals only if the requirements of this Regulation, as amended by the 02 series of amendments are satisfied.
- 10.3. As from 1 October 2006 Contracting Party applying this Regulation may refuse to recognize approvals which were not granted in accordance with the 02 series of amendments to this Regulation.
- 10.4. As from the official date of entry into force of the 03 series of amendments, no Contracting Party applying this Regulation shall refuse to grant ECE approval under this Regulation as amended by the 03 series of amendments.
- 10.5. As from 72 months after the date of entry into force of the 03 series of amendments Contracting Parties applying this Regulation shall grant ECE approval under this Regulation to the new types of cabs only if the requirements of this Regulation, as amended by the 03 series of amendments, are satisfied.
- 10.6. Contracting Parties applying this Regulation shall not refuse to grant extensions of approval to the preceding series of amendments to this Regulation.
- 10.7. Contracting Parties applying this Regulation shall continue to grant approvals to those types of vehicles which comply with the requirements of this Regulation as amended by the preceding series of amendments during the 72 months' period which follows the date of entry into force of the 03 series of amendments.
- 10.8. No Contracting Party applying this Regulation shall refuse national or regional type approval of a vehicle type approved to the 03 series of amendments to this Regulation.
- 10.9. Even after the entry into force of the 03 series of amendments to this Regulation, approvals of the vehicles to the preceding series of amendments to this Regulation shall remain valid and Contracting Parties applying this Regulation shall continue to accept them.

11. Names and addresses of Technical Services responsible for conducting approval tests and of Type Approval Authorities

The Parties to the Agreement which apply this Regulation shall communicate to the Secretariat of the United Nations the names and addresses of the Technical Services conducting approval tests, and of the Type Approval Authorities which grant approval and to which forms certifying approval or extension, or refusal or withdrawal of approval, issued in other countries, are to be sent.

Annex 1 - ECE type-approval documentation

Part 1 - Model information document

Pursuant to Regulation No. 29 relating to type-approval of the cab

The following information, if applicable, must be supplied in triplicate and include a list of contents. Any drawings must be supplied in appropriate scale and in sufficient detail on size A4 or on a folder of A4 format. Photographs, if any, must show sufficient detail.

1. General
- 1.1. Make (trade name of manufacturer):
- 1.2. Type:
- 1.3. Means of identification of type, if marked on the vehicle:
- 1.3.3. Location of that marking:
- 1.4. Category of vehicle¹:
- 1.5. Name and address of manufacturer:
- 1.6. Address(es) of assembly plant(s):
2. General Construction Characteristics of the Vehicle
- 2.1. Photographs and/or drawings of a representative vehicle:
- 2.2. Dimensional drawing of the whole vehicle:
- 2.3. Number of axles and wheels:
- 2.6. Position and arrangement of the engine:
- 2.7. Driving cab (cab-over-engine or bonnet)²
- 2.8. Hand of drive:
3. Masses and Dimensions (in kg and mm) (refer to drawing where applicable)
- 3.1. Technically permissible maximum laden mass stated by the manufacturer:
- 3.2. Technical permissible maximum mass for the front axle or axles of the vehicle:
4. Cab
- 4.1. Type of cab: (normal/sleeper/top-sleeper)³:

¹ As defined in the Consolidated Resolution on the Construction of Vehicles (R.E.3.), document ECE/TRANS/WP.29/78/Rev.2, para. 2

² Cab-over-engine means a configuration in which more than half of the engine length is rearward of the foremost point of the windshield base and the steering wheel hub in the forward quarter of the vehicle length.

³ Delete where not applicable (there are cases where nothing needs to be deleted when more than one entry is applicable).

- 4.2. Materials used and methods of construction:
- 4.3. Door configuration and number of doors:
- 4.4. Drawings of door latches and retention components and their position in the doors:
- 4.5. Number of seats:
- 4.6. R-points:
- 4.7. Detailed description of the cab of the vehicle type including its dimensions, configuration and constituent materials and its attachment to any chassis frame:
- 4.8. Drawings of the cab and those parts of its interior arrangement which have an influence on the residual space:
- 5. Steering
- 5.1. Schematic diagram(s) of the steering control(s):
- 5.2. Range and method of adjustment (if any), of the steering control:

Annex 1 - Part 2

Communication

(maximum format: A4 (210 x 297 mm))



issued by:
Name of administration:
.....

concerning²: APPROVAL GRANTED
APPROVAL EXTENDED
APPROVAL REFUSED
APPROVAL WITHDRAWN
PRODUCTION DEFINITELY DISCONTINUED

of a vehicle type with regard to protection of the occupants of the cab of a vehicle pursuant to Regulation No. 29.

Approval No: Extension No:

1. Trade name or mark of the vehicle:
2. Vehicle type:
3. Manufacturer's name and address:
4. If applicable, name and address of manufacturer's representative:
5. Brief description of the cab's design and method of attachment:
6. Vehicle submitted for approval on:
7. Technical Service responsible for conducting approval tests:
8. Date of report issued by that service:
9. Number of report issued by that service:
10. Approval granted/refused/extended/withdrawn²
11. Position of approval mark on the vehicle:
12. Place:
13. Date:
14. Signature:

The list of documents deposited with the Type Approval Authority which has granted approval is annexed to this communication and may be obtained on request.

¹ Distinguishing number of the country which has granted/extended/refused or withdrawn approval.

² Strike out what does not apply.

Annex 2

Arrangements of approval marks

Model A
(See paragraph 4.4. of this Regulation)

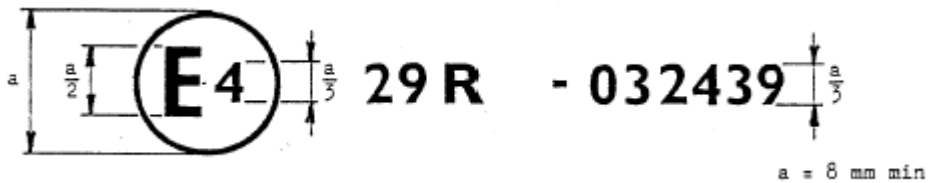

The above approval mark affixed to a vehicle shows the vehicle type concerned has with regard to the protection of the occupants of the cab of a commercial vehicle, been approved in the Netherlands (E 4), under the number 03249. The first two digits of the approval number indicate the Regulation No. 29 already included the 03 series of amendments when the approval was given.

Model B

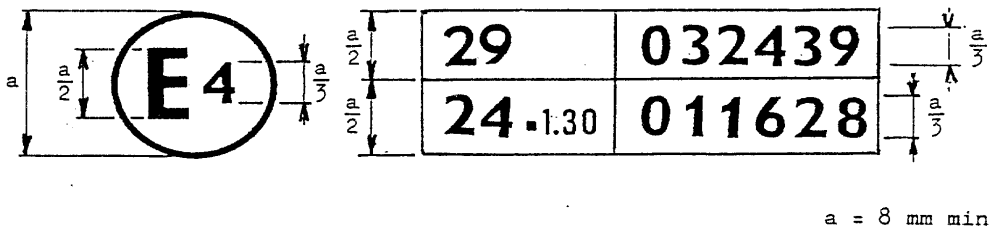

The above approval mark affixed to a vehicle shows that the vehicle type concerned has been approved in the Netherlands (E 4) pursuant to Regulations Nos. 29 and 24¹ (In the case of the latter Regulation the corrected absorption coefficient is 1.30 m⁻¹. The approval numbers indicate that on the dates on which these approvals were granted, Regulations Nos. 29 and 24 included the 03 series of amendments.

¹ The second number is given merely as an example.

Annex 3

Test procedure

1. Doors
Before the tests the doors of the cab shall be closed but not locked.
2. Engine
For test A the engine, or a model equivalent thereto in mass, dimensions and mounting, shall be fitted to the vehicle.
3. Cab
The cab shall be equipped with the steering mechanism, steering wheel, instrument-panel and the driver and passenger seats. The steering wheel and the seating position shall be adjusted to their positions for normal use as prescribed by the manufacturer.
4. Anchorage of the cab
For test A, the cab shall be mounted on a vehicle. For tests B, C the cab shall, at the manufacturer's choice, be mounted either on a vehicle or on a separate frame. The vehicle or frame shall be secured in the manner prescribed in Appendix 1 to this annex.
5. Front impact test (test A)

Figure 1
Front impact test (test A)

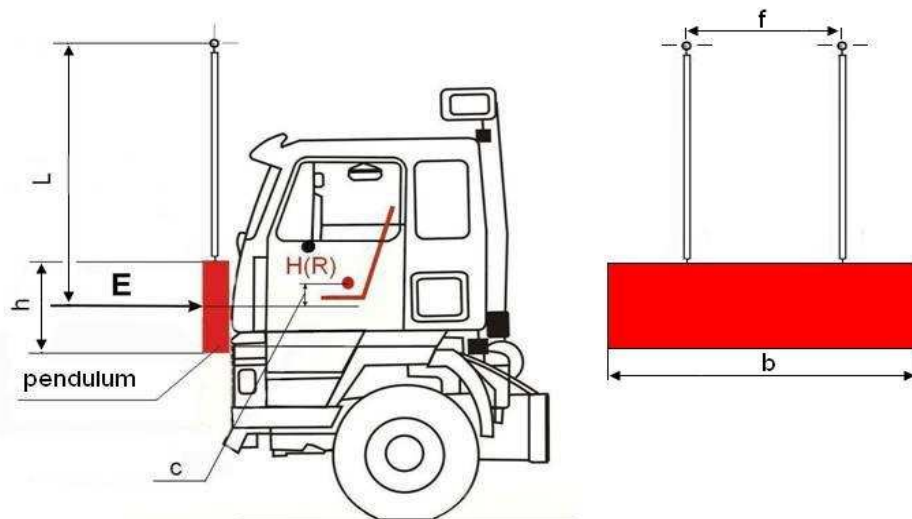

- 5.1. The impactor shall be made of steel and its mass shall be evenly-distributed; its mass shall not be less than 1,500 kg. Its striking surface, rectangular and flat, shall be 2,500 mm wide and 800 mm high (see b and h on figure 1). Its edges shall be rounded to a radius of curvature of $10\text{ mm} \pm 5\text{ mm}$.
- 5.2. The impactor assembly shall be of rigid construction. The impactor shall be freely suspended by two beams rigidly attached to it and spaced not less than 1,000 mm apart (see f on figure 1). The beams shall be not less than 3,500 mm long from the axis of suspension to the geometric centre of the impactor (L on figure 1).
- 5.3. The impactor shall be so positioned that in the vertical position:
 - 5.3.1. Its striking face is in contact with the foremost part of the vehicle;
 - 5.3.2. Its centre of gravity is $c=50 +5/ - 0\text{ mm}$ below the R point of the driver's seat, and
 - 5.3.3. its centre of gravity is in the median longitudinal plane of the vehicle.
- 5.4. The impactor shall strike the cab at the front in the direction towards the rear of the cab. The direction of impact shall be horizontal and shall be parallel to the median longitudinal plane of the vehicle.
- 5.5. The impact energy shall be:
 - 5.5.1. 29.4 kJ in the case of vehicles of category N_1 and of vehicles of category N_2 with a gross vehicle mass not exceeding 7.5 t.
 - 5.5.2. 55 kJ in the case of vehicles of category N_3 and of vehicles of category N_2 with a gross vehicle mass exceeding 7.5 t.
6. Front pillar impact test (Test B)

Figure 2
Front pillar impact test (Test B)

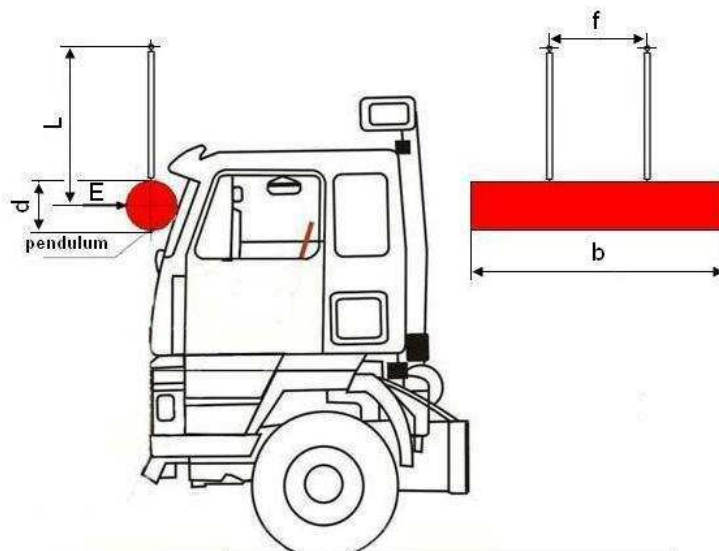

- 6.1. The impactor shall be rigid and its mass shall be evenly-distributed; its mass shall not be less than 1,000 kg. The impactor shall be cylindrical with a diameter d of the cylinder of 600 ± 50 mm and a length b of not less than 2,500 mm. Its edges shall be rounded to a radius of curvature of not less than 1.5 mm.
- 6.2. The impactor assembly shall be of rigid construction. The impactor shall be freely suspended by two beams rigidly attached to it and spaced not less than $f = 1,000$ mm apart. The beams shall not be less than $L = 3,500$ mm long from the axis of suspension to the geometric centre of the bob impactor.
- 6.3. The impactor shall be so positioned that when its suspension is in the vertical position:
 - 6.3.1. Its striking face is in contact with the foremost part of the cab;
 - 6.3.2. Its median longitudinal line is horizontal and perpendicular to the median longitudinal vertical plane of the cab;
 - 6.3.3. Its center of gravity is midway between the lower and the upper windscreen frame, as measured along the windscreen and along the median longitudinal vertical plane of the cab;
 - 6.3.4. Its centre of gravity is in the median longitudinal plane of the cab;
 - 6.3.5. Its length is equally distributed over the width of the vehicle, overlapping the full width of both A-pillars.
- 6.4. The impactor shall strike the cab at the front in the direction towards the rear of the cab. The direction of impact shall be horizontal and shall be parallel to the median longitudinal plane of the vehicle.
- 6.5. The impact energy shall be 29.4 kJ
7. Roof strength test (Test C)

Figure 3
Roof strength test (Test C)

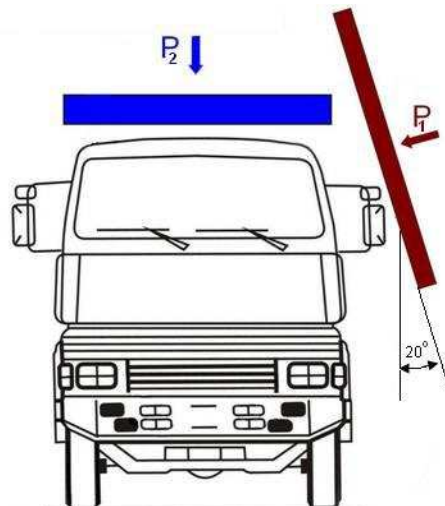

- 7.1. For vehicles of category N₂ with a gross vehicle mass exceeding 7.5 t and of category N₃, both tests as described in paragraphs 7.3. and 7.4. below, in that order, shall be conducted on the same cab.
- 7.2. For vehicles of category N₂ with a gross vehicle mass not exceeding 7.5 t and of category N₁, only the test as described in paragraph 7.4. below shall be conducted.
- 7.3. Dynamic pre-loading of vehicles of category N₂ with a gross vehicle mass exceeding 7.5 t and of category N₃ (see P₁ on figure 3).
 - 7.3.1. The impactor shall be rigid and its mass shall be evenly distributed; its mass shall not be less than 1,500 kg.
 - 7.3.2. The striking surface of the impactor shall be rectangular and flat. Its dimensions shall be sufficiently large such that, when positioned in accordance with paragraph 7.3.3. below, no contact will occur between the cab and the edges of the impactor.
 - 7.3.3. The impactor and/or the cab shall be so positioned that, at the time of impact:
 - 7.3.3.1. The striking face of the impactor is at an angle of 20° to the median longitudinal plane of the cab. Either the impactor or the cab may be tilted;
 - 7.3.3.2. The striking face of the impactor covers the whole length of the top side of the cab;
 - 7.3.3.3. The median longitudinal line of the impactor is horizontal and parallel to the median longitudinal plane of the cab.
 - 7.3.4. The impactor shall strike the upper side of the cab such that at the time of the impact the prescriptions of paragraph 7.3.3. above are satisfied. The direction of impact shall be perpendicular to the surface of the impactor and perpendicular to the median longitudinal line of the cab. Either the impactor or the cab may be moving, as long as the positioning requirements are satisfied.
 - 7.3.5. The impact energy shall be minimum 17.6 kJ.
- 7.4. Roof strength test (see P₂ on figure 3)
 - 7.4.1. The loading device shall be made of steel and its mass shall be evenly distributed.
 - 7.4.2. The loading face of the device shall be rectangular and flat. Its dimensions shall be sufficiently large such that, when positioned in accordance with paragraph 7.4.4. below, no contact will occur between the cab and the edges of the device.
 - 7.4.3. A linear bearing system may be included between the device and its supporting structure to allow for lateral motion of the cab roof away from the side that was impacted in the pre-load phase of paragraph 6.3., if applicable.
 - 7.4.4. The loading device shall be so positioned that, during the test:
 - 7.4.4.1. It is parallel to the x-y plane of the chassis;
 - 7.4.4.2. It moves parallel to the vertical axis of the chassis;
 - 7.4.4.3. Its loading face covers the whole area of the cab roof.
 - 7.4.5. A static load shall be applied by the loading device to the roof of the cab, corresponding to the maximum mass authorised for the front axle or axles of the vehicle, subject to a maximum of 98 kN.

Annex 3 - Appendix 1

Instructions for securing vehicles to the test bed

1. Frontal impact

Test A shall be applied to a cab mounted on the vehicle in the following way (see figure 1 below).
- 1.1. Anchoring chains or ropes

Each anchoring chain or rope shall be of steel and shall be capable of withstanding a tractive load of at least 10 tons.
- 1.2. Blocking of the chassis frame

The longitudinal members of the chassis frame shall be supported on wooden blocks across their full width and over a length of not less than 150 mm. The front edges of the blocks must not be situated forward of the rearmost point of the cab, nor rearward of the mid-point of the wheel base. At the manufacturer's request the chassis frame shall be set in the attitude it takes up when loaded.
- 1.3. Longitudinal attachment

Rearward movement of the chassis frame shall be limited by chains or ropes A attached to the front of the chassis frame symmetrically in relation to its longitudinal axis, the points of attachment being not less than 600 mm apart. The chains or ropes shall when tensioned form a downward angle of not more than 25° with the horizontal and their projection on a horizontal plane shall form an angle of not more than 10° with the longitudinal axis of the vehicle. The chains or ropes may cross one another.
- 1.4. Lateral attachment

Lateral movement shall be limited by chains or ropes B attached to the chassis frame symmetrically in relation to its longitudinal axis. The points of attachment to the chassis shall be not more than 5 m and not less than 3 m from the front of the vehicle. The chains or ropes shall when tensioned form a downward angle of not more than 20° with the horizontal and their projection on a horizontal plane shall form an angle of not less than 25° and not more than 45° with the longitudinal axis of the vehicle.
- 1.5. Tensioning of chains or ropes and rear attachment

The chain or rope C shall, to begin with, be placed under a load of approximately 1 kN. All slack in the four chains or ropes A and B shall then be taken up and chain or rope C shall be subjected to a tensile stress of not less than 10 kN. The angle of chain or rope C with the horizontal shall not exceed 15°. A vertical blocking force of not less than 500 N shall be applied at point D between the chassis frame and the ground.

- 1.6. Equivalent mounting

At the request of the manufacturer the test may be carried out with the cab mounted on a special frame, on condition that this method of mounting is shown to be equivalent to mounting on the vehicle.
2. Front pillars impact
 - 2.1. Cab mounted on the vehicle (see fig. 1)

Measures shall be taken to ensure that the vehicle does not shift appreciably during the test. For this purpose the hand-brake shall be applied, a gear engaged and the front wheels wedged with chocks.
 - 2.2. Cab mounted on a frame

Measures shall be taken to ensure that the cab does not shift appreciably during the test.
3. Roof strength
 - 3.1. Cab mounted on the vehicle

Measures shall be taken to ensure that the vehicle does not shift appreciably during the test. For this purpose the hand-brake shall be applied, a gear engaged and the front wheels wedged with chocks. Deformation of the various components of the suspension (springs, tyres, etc.) shall be eliminated by means of rigid members.
 - 3.2. Cab mounted on a frame

Measures shall be taken to ensure that the frame does not shift appreciably during the test.

Figure 1 - Front impact test
The cab is mounted on the vehicle

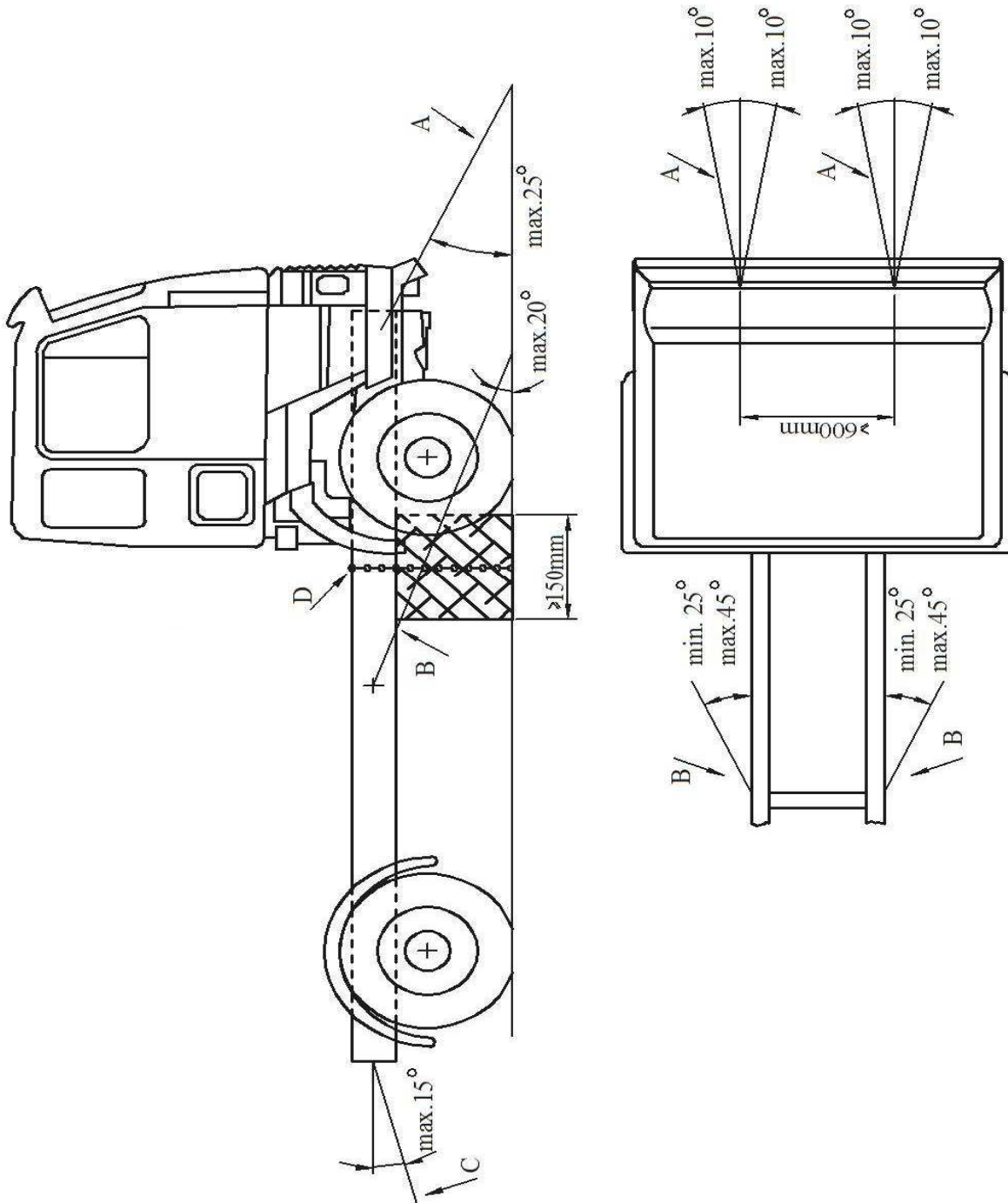

Annex 3 - Appendix 2

Manikin to be used to verify the survival space

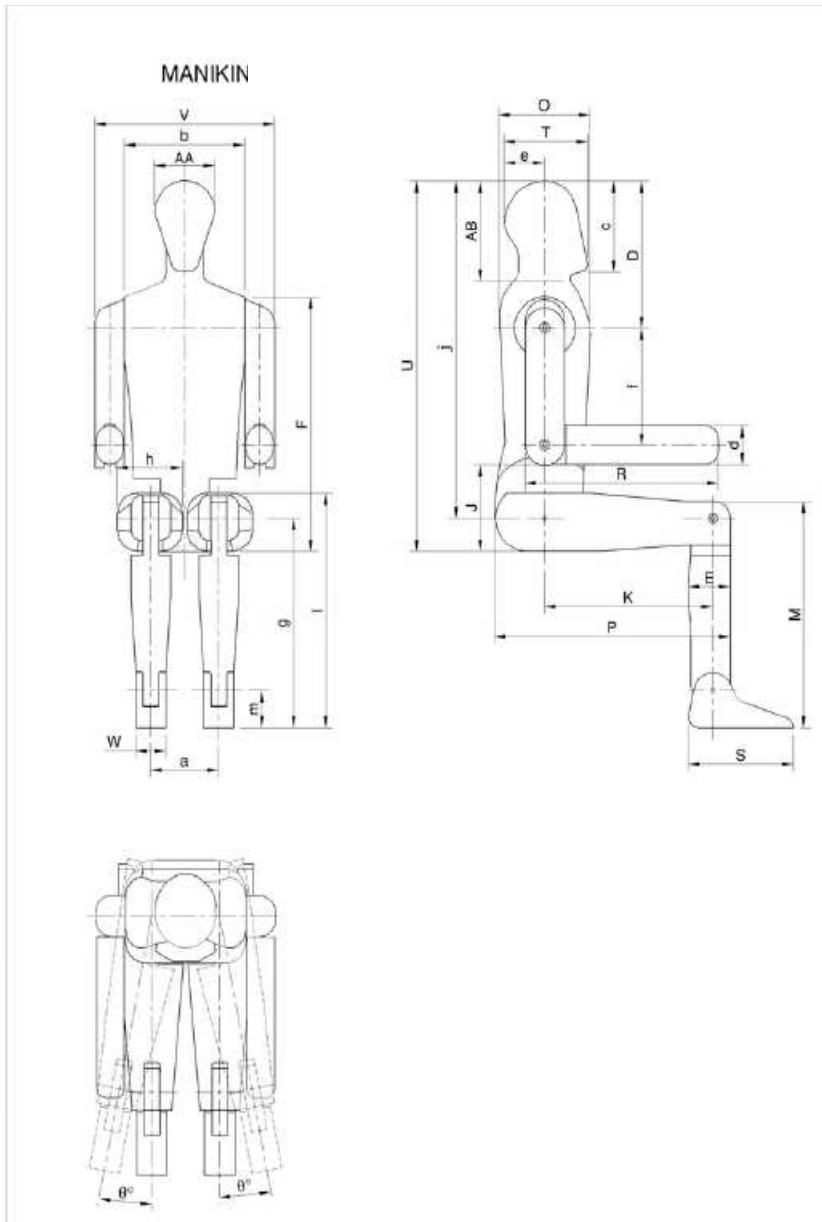

<i>Dimensions</i>		
<i>Name</i>	<i>Description</i>	<i>Dimension, in mm</i>
AA	Breadth of head	153
AB	Combined height of head and neck	244
D	Distance from top of head to shoulder pivot	359
E	Calf depth	106
F	Height from seat to top of shoulder	620
J	Height of elbow rest	210
M	Knee height	546
O	Chest depth	230
P	Distance from seat back to knee	595
R	Distance from elbow to fingertip	490
S	Length of foot	266
T	Length of head	211
U	Height from seat to top of head	900
V	Shoulder breadth	453
W	Breadth of foot	77
a	Distance between hip point centers	172
b	Chest breadth	305
c	Height of head and chin	221
d	Forearm thickness	94
e	Distance between vertical centerline of torso and rear of head	102
f	Distance between shoulder pivot and elbow pivot	283
g	Knee pivot height from ground	505
h	Thigh breadth	165
i	Lap height (Sitting)	565
j	Distance from top of head to "H" point	819
k	Distance between hip pivot and knee pivot	426
m	Ankle pivot height from ground	89
θ	Lateral rotation of the legs	20°

Annex 4

Procedure for determining the "H" point and the actual torso angle for seating positions in motor vehicles¹

¹ The procedure is described in Annex 1 to the Consolidated Resolution on the Construction of Vehicles (R.E.3) document (ECE/TRANS/WP.29/78/Rev.2).

Annex 4 - Appendix 1

Description of the three-Dimensional "H" point machine (3-D H machine)¹

¹ The 3-D H machine is described in Annex 1, Appendix 1 to the Consolidated Resolution on the Construction of Vehicles (R.E.3) document (ECE/TRANS/WP.29/78/Rev.2).

Annex 4 - Appendix 2

Three-dimensional reference system¹

¹ As described in Annex 1 Appendix 2 to the Consolidated Resolution on the Construction of Vehicles (R.E.3) document (ECE/TRANS/WP.29/78/Rev.2).

Annex 5

Reference data concerning seating positions¹

¹ As described in Annex 1, Appendix 3 to the Consolidated Resolution on the Construction of Vehicles (R.E.3) document (ECE/TRANS/WP.29/78/Rev.2).