



## **Durite Ultrasonic Side Scan System 10-32VDC Part 0-870-10**

### **WARNINGS**

Before using this unit please read these instructions carefully. Take special care to follow the warnings indicated on the unit itself as well as the safety suggestions listed below. Keep these instructions for future reference.

### **GENERAL**

The intelligent ultrasonic side sensor system is designed for commercial vehicles upto 12M in length such as bus, caravan and heavy duty vehicles. For longer articulated vehicles a suzi cable (0-870-95) can be supplied. The system provides active warning with audible beeping alerts, and alerts you to objects as far as 1.8M away. What's more, it's connected with an external alarm installed at the outer side of the vehicle to warn the moving hazard such as a pedestrian, cyclist, cars and so on. The application is flexible. There are two mounting methods including flush mount and suspended mount. This fully integrated safety solution is compatible with any Durite camera and monitor meaning you can add value to your existing safety reversing vehicle system by including a side scan kit. The graphic is displayed on the monitor to provide a visual aid as well as an audible alert for both driver and vulnerable pedestrians, cyclist etc.



### **SYSTEM COMPONENTS**

- 1 x ECU Control Module (0-870-92)
- 4 x Ultrasonic Sensor
- 4 x Sensor Extension Cable 2.2M (0-870-91)
- 1 x Sensor Main Extension Cable 9.2M (0-870-90)
- 1 x Main Wire Harness
- 1 x Sleeve Set (4°, 8° and 12°) x 4/pcs each set
- 4 x Suspended Bracket
- 1 x External Audible Alarm ("This vehicle is turning left") (0-564-60)

# SYSTEM DIAGRAM - 4 Sensors

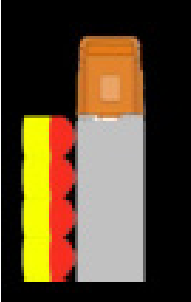
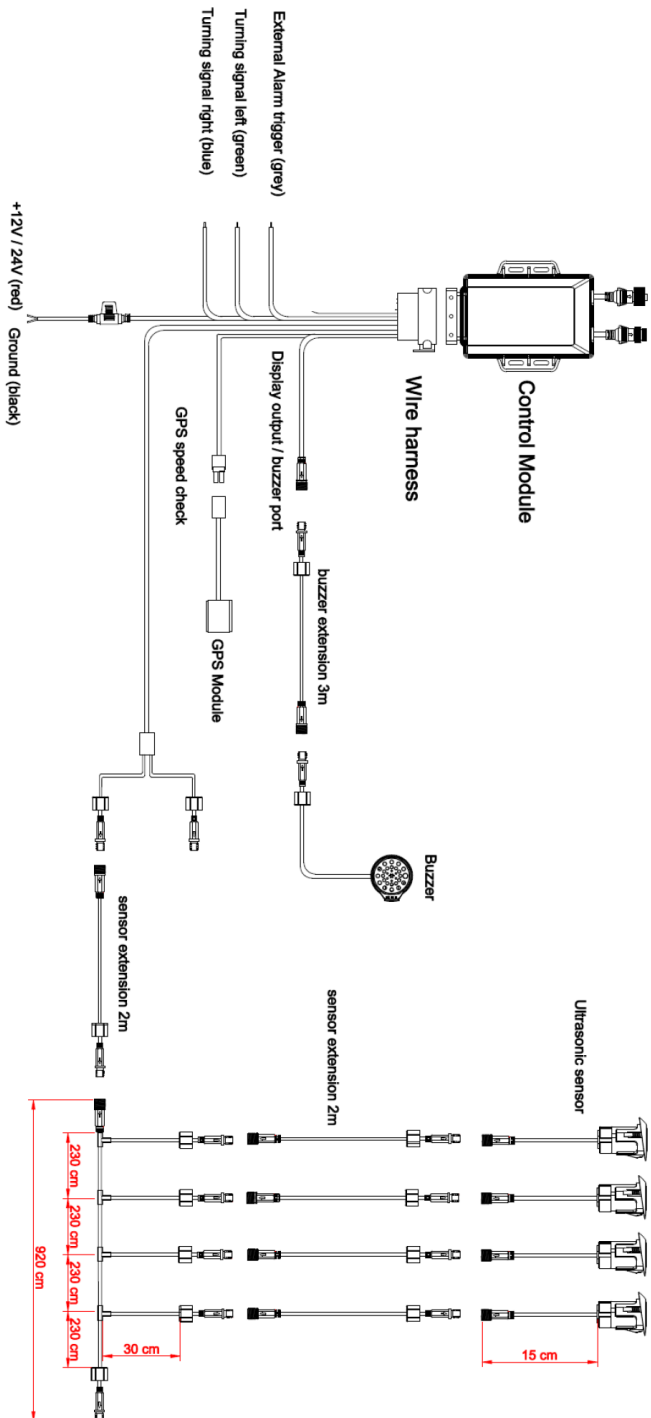

Additional sensors can be added to support an 8 or 12 sensors application on the left (near) side of the vehicle. Please see the extended diagram below for how this can be achieved.

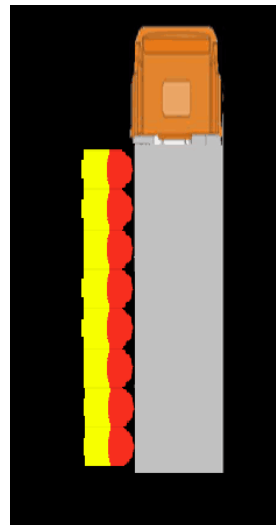
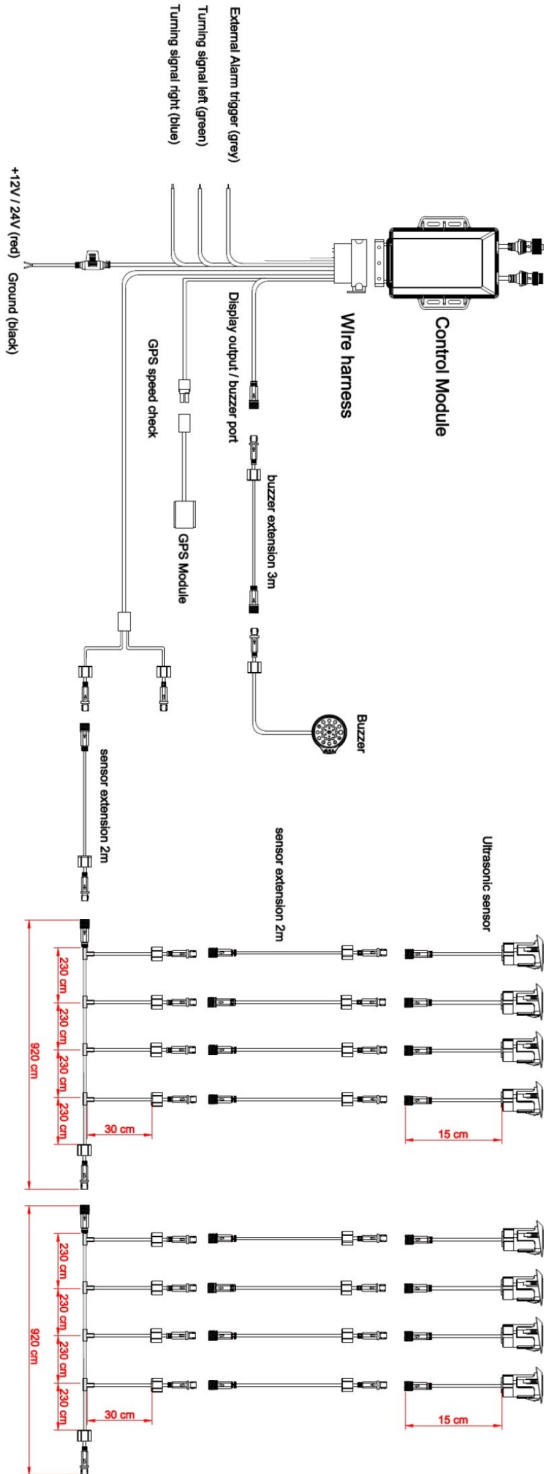



## **SYSTEM DIAGRAM**

Red and black on the monitor and control box side should be connected at the same time. If you use CAM1 connector on the monitor side to connect the control box, the corresponding trigger wire should be connected to the positive power input.

The system can connect up to 4 sensors and can be used either side. Furthermore, 8 or 12 sensors can also be installed one side if they are purchased additionally (please see diagrams on the previous pages). Before making the connection disconnect the ground terminal of the vehicle battery to avoid short circuits. The plugs should be fully inserted into the connection or jacks. A loose connection may cause malfunction of the unit.

Note: Upon activation the system will check the sensor status. A green colour block will be displayed on the screen if sensor is in good status, otherwise it will be marked with a red block. Check all connections if this occurs. Connect power cable to 12V/24V power source to drive side sensor system. External alarm or camera need to be powered separately.

Graphic display:

When working with a monitor, the system will overlay the vehicle image on the screen. On detection, if obstacle is within 90cm range from sensor, it will be marked with a red block while for 90cm-180cm distance it'll be a yellow block. Graphic is auto-adjusted to reflect the number of sensors activated.

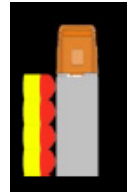

### **Switch function:**

Adjust the red switch on the control box to confirm different series of speed you need under different traffic condition.

**Switch 1: down:** the buzzer will make the warning when the obstacle are within 0.9M dependent on speed and indicator - see settings page 10.

**Switch 2: up:** left side installation (display on right side of screen) **down:** right side installation

(display on left side of screen)

**Switch 3 : down & Switch 4: up**

The system sensors are active and the internal cab buzzer will provide an audible alert upon detection regardless of indicator trigger input.

**Switch 3 : up & Switch 4: down**

When the vehicle speed is increasing with turning signal, the system will do the detection along with the visual warning and audible warning within 0-25MPH.

It will stop working while the vehicle speed is above 25MPH. When the vehicle speed is decreasing with turning signal, the system will do the detection along with the visual warning and audible warning within 0-22MPH. It will stop working while the vehicle speed is above 22MPH

**Switch 3: up & Switch 4: up**

When the vehicle speed is increasing with turning signal, the system will do the detection along with the visual warning and audible warning within 0-15MPH. It will stop working while the vehicle speed is above 15MPH. When the vehicle speed is decreasing with turning signal, the system will do the detection along with the visual warning and audible warning within 0-12MPH.

It will stop working while the vehicle speed is above 12MPH

**Switch 5 UP:** Heavy Truck image displayed as graphic on monitor

**Switch 5 DOWN:** Bus image displayed as graphic on monitor

**Switch 6:** reserved

## INSTALLATION

It is advised that a professional and qualified technician installes this product.

Choose and mark installation locations. Choose a suitable location, measure the height to the ground and then mark its location.

Sensor Installation: Suspended Sensor.

It is strongly advised to mount the sensor at least 45cm from the ground (with vehicle fully loaded). Insert sensor into mounting housing, put rubber pad in place and use screws to fix the sensors on to the vehicle.

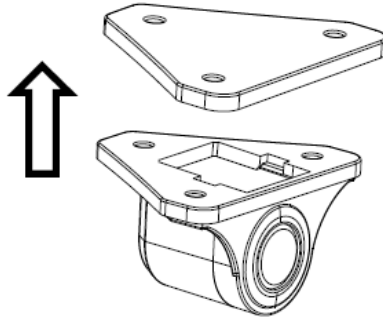

Drill hole type sensor:

Measure the angle of installation location. Check the below table and use sensor sleeves in installation kit to adjust the sensor to optimized angle.

Mounting Height	Optimized Sensor Angle
40 – 50cm	13°
50 – 60cm	9°
60 – 70cm	6°
70 – 80cm	3°
80 – 90cm	0°
90 – 100cm	-3°

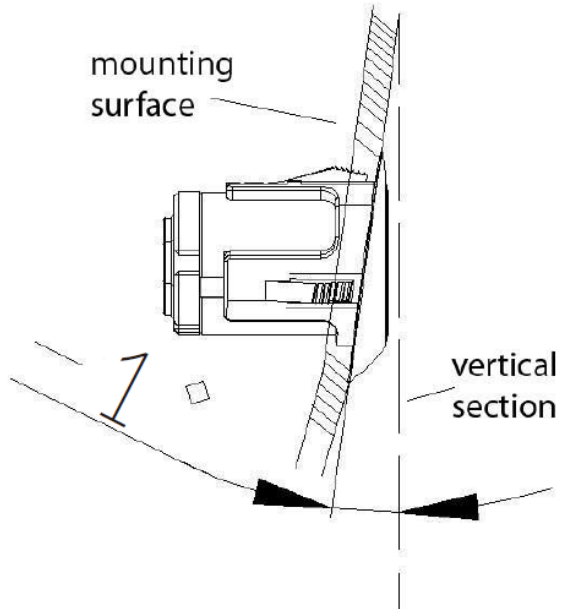

There are three kinds of (4°/8°/12°) sleeves to choose from. For example, for a location with a 50cm mounting height and -1°angle against vertical section (as shown in above picture).Then the computing method is:

Low limit angle( $9^\circ$ ) $\leq$ sensor sleeve angle+mounting position angle ( $-1^\circ$ ) $\leq$ high limit angle( $13^\circ$ )

So it is clear that 12°sensor sleeve is needed to adjust the sensor to the optimized angle.

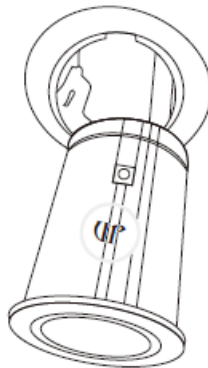

Drill 24mm hole, push sensor sleeve into the hole. There's a marking on the sensor bracket, please make sure this marking faces upward. Then insert sensor into the sleeve.

#### Control Box Installation:

Mount control box to a flat location, make sure the sensor cables are long enough to reach the control module.

#### Cable Connection:

Make sure the sensors are connected to correct ports on the control module, then connect control module with camera and monitor.

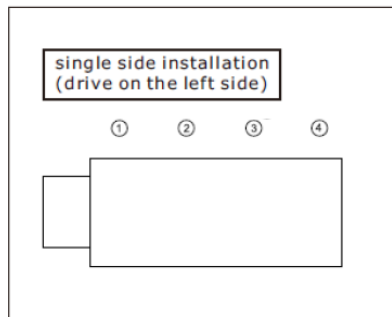
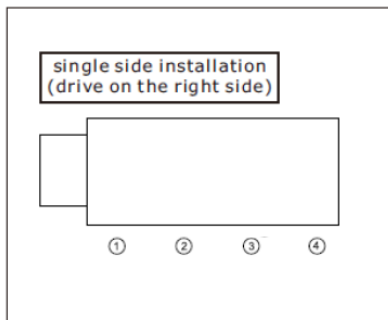



## ENVIRONMENT LEARNING MODE

1



For example, if there is a tow bar, the back of truck and the system always detects it and sends false alarm.

**FALSE BEEP**

3

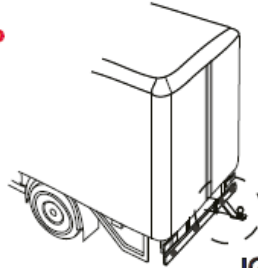

**IGNORE**

- 2 Quickly switch on and off the detection system for three times.

Then, the system will ignore the tow bar.

## CONTROL BOX SETTINGS

### System Activation By Vehicle Signal

When the system detects objects and side turn indicator lights are triggered, the system gives the driver a visual and audible warning. At the same time, it alerts moving object such as a pedestrian, cyclist and/or cars through an alarm installed on the outer-side of the vehicle. The range of warning is 1.8M (when the obstacle is within 1.8M, it will do the warning). In the DOWN position Switch 1 will decrease the warning range to 0.9M. If side turn indicators lights are not triggered, the system only give the driver visual warning. The vehicle image is always displayed on the monitor, if there is a turn signal from the side with CAM 1 is installed the camera image will be displayed on screen.

See the tables below for the different speed settings:

### NOTE:

Some vehicle's have a continuous CANBUS diagnostic check resulting in 7.0 - 8.0VDC being present in the circuit at all times. In this instance, a Zener diode (part number 0-834-05 for 24V and 0-834-04 for 12V) will be required between each indicator feed and trigger. This will stop the detection system being triggered incorrectly which would result in no output signal from the ECU.

Condition	Internal Buzzer (when Indicating)	External turning alarm (when Indicating)	Internal Buzzer (when NOT Indicating)	External turning alarm (when NOT Indicating)	Sensor Display on-screen
Speed > 65km/h	OFF	OFF	OFF	OFF	OFF
15 / 12 MPH (3↗ 4↘)	✓	✓	OFF	OFF	✓
Below cut-off speed (15Mph if accelerating, 12Mph if decelerating)					
Above cut-off speed (3↗ 4↘)	OFF	OFF	OFF	OFF	✓
Below cut-off speed (20Mph if accelerating, 17Mph if decelerating)					
20 / 17 MPH (3↘ 4↗ / 3↘ 4↗)	✓	✓	✓	OFF	✓
Below cut-off speed (20Mph if accelerating, 17Mph if decelerating)					
Above cut-off speed (3↘ 4↗ / 3↘ 4↗)	OFF	OFF	OFF	OFF	✓
Below cut-off speed (20Mph if accelerating, 17Mph if decelerating)					
25 / 22 MPH (3↗ 4↘)	✓	✓	OFF	OFF	✓
Below cut-off speed (25Mph if accelerating, 22Mph if decelerating)					
Above cut-off speed (3↗ 4↘)	OFF	OFF	OFF	OFF	✓
Below cut-off speed (25Mph if accelerating, 22Mph if decelerating)					

\* Indicating signal only works when it's from the same side where sensor is mounted.

\* Receiving indicating signal from both sides will be viewed as using hazard light, system will act as if there is NO indicating signal received

### **DISCLAIMER**

In the below case an object might not be detected:

- (1) A small object, which is under your bumper or too close to the vehicle, may not be detected.
- (2) When reversing down a steep slope or driveway, gravel and/or the road surface may cause momentary detection signal.
- (3) Reversing on loose gravel, rough surface, and pot holes may produce intermittent detection.
- (4) Reversing at an angle towards a partial wall or other large flat surface may refract ultrasonic signals.
- (5) If reversing towards a 90° angle such as a corner of a wall or a pillar.
- (6) Due to natural projection angle of the sensors, a nature "no coverage" area is common with the system at the outer corners of the vehicle, this may occur at about 0-10mm from the bumper's outer corners.

**Note:** This system should only be used as an assistant tool for driving and parking vehicles, User should make judgments at his own discretion. Durite and our products take NO responsibility for traffic accidents caused by driving and parking.

### **SPECIFICATION**

Operation Voltage.....	10-32VDC
Current Consumption.....	300Ma (Max)
External Trigger (Grey).....	20-40Ma
Operation Temperature.....	-20°C to + 70°C
Storage Temperature.....	-40°C to 85°C
Ultrasonic Frequency.....	58KHz +/- 2KHz
Detection Range.....	0-180cm
Max Vehicle Length.....	12M (Suzi Cable Option Available For Artics)
IP Rating.....	IP68
OSDTV System.....	NTSC/PAL
Video Signal.....	1.0Vp-p @ 75ohm
Certificate.....	E Marked ECE EMC R10